

**TECHNICAL BULLETIN**

**OCCUPATIONAL AND ENVIRONMENTAL HEALTH  
RECREATIONAL WATER FACILITIES**

**APPROVED FOR PUBLIC RELEASE; DISTRIBUTION IS UNLIMITED.  
HEADQUARTERS, DEPARTMENT OF THE ARMY**

**RECREATIONAL WATER FACILITIES**

You can help to improve this bulletin. If you find any mistakes or have a recommendation to improve procedures, please let us know. Mail a memorandum or DA Form 2028 (Recommended Changes to Publications and Blank Forms) directly to the Office of The Surgeon General, ATTN: DASG-PPM-NC, 7700 Arlington Boulevard, Falls Church, VA 22041.

		Paragraph	Page
CHAPTER 1	INTRODUCTION		
	Purpose	1-1	1
	Applicability	1-2	1
	References	1-3	2
	Explanation of abbreviations and terms	1-4	2
	Preventive medicine/public health responsibilities	1-5	2
	Other responsibilities	1-6	2
CHAPTER 2	DESIGN STANDARDS FOR AQUATIC VENUES		
Section I	Type and Location of aquatic venues		
	Recirculation swimming pool with filters	2-1	3
	Wading pools	2-2	3
	Spray pools	2-3	4
	Aquatic play features	2-4	5
	Flow-through swimming pools	2-5	6
	Fill and draw swimming pools	2-6	7
	Spas	2-7	7
	Therapy pools	2-8	8

---

\* This bulletin supersedes TB MED 575, 2 July 1993.

	Paragraph	Page
Section II	Design and Construction Details	
	General	2-9 8
	New construction pre-opening inspection	2-10 9
	Designated areas	2-11 9
	Bather load	2-12 9
	Materials	2-13 10
	Markings	2-14 10
	Water supply	2-15 12
	Accessible means of entry	2-16 12
	Bottom slope, side walls, and safety ledges	2-17 13
	Steps and ladders	2-18 13
	Connections for safety lines	2-19 14
	Decks and adjacent areas	2-20 14
	Diving areas	2-21 15
	Swimming pool slides and flumes	2-22 15
Section III	Disinfection	
	Types of disinfectants	2-23 16
	Disinfection of aquatic facility water	2-24 17
	Oxidation reduction potential	2-25 20
	Disinfection using chlorine	2-26 20
	Electrolytic chlorine generators	2-27 22
	Cyanuric acid	2-28 23
	Disinfection using bromine	2-29 23
	Ozone disinfection	2-30 24
	Ultraviolet disinfection	2-31 24
	Disinfection using ion-generating devices	2-32 24
	Prohibited disinfection practices	2-33 25
Section IV	Recirculation	
	General	2-34 25
	Recirculation system appurtenances	2-35 25
	Inlets	2-36 27
	Outlets	2-37 27
	Main drains	2-38 28
	Overflow gutters	2-39 30
	Skimmers	2-40 31
	Pumps	2-41 32
	Piping	2-42 32
	Strainer baskets	2-43 32
	Vacuum cleaners	2-44 32
	Flow rate	2-45 33

		Paragraph	Page
Section V	Filtration		
	Filtration	2-46	33
	Standard filter requirements	2-47	33
	Sand filters	2-48	34
	Diatomaceous filters	2-49	34
	Cartridge filters	2-50	34
Section VI	Maintenance and Water Quality		
	Cleaning aquatic facilities	2-51	35
	Algae	2-52	35
	Winterizing	2-53	36
Section VII	Bathhouse Facilities		
	General	2-54	36
	Dressing rooms	2-55	37
	Showers	2-56	37
	Toilet facilities	2-57	38
	Footbaths	2-58	38
Section VIII	Utilities		
	Heating	2-59	38
	Ventilation	2-60	39
	Lighting	2-61	39
	Electrical	2-62	40
Section IX	Spectator and Concession Areas		
	Spectator areas	2-63	40
	Concession areas	2-64	40
Section X	Landscaping, Fencing, and Enclosures		
	Landscaping	2-65	41
	Fencing and enclosures	2-66	41
CHAPTER 3	NATURAL BATHING AREA DESIGN		
	General	3-1	43
	Natural bathing area design	3-2	43
	Depth and type of sand	3-3	44
	Diving areas	3-4	44
	Support facilities	3-5	44
	Beach operations	3-6	45
CHAPTER 4	HEALTH AND SAFETY CONSIDERATIONS		
Section I	Health Considerations in Aquatic Venues		

	Paragraph	Page
	Sanitation and disease transmission	4-1 46
	Diseases	4-2 48
	Monitoring devices	4-3 49
	Bacteriological water quality	4-4 50
	Bacteriological laboratory analyses	4-5 51
	Collection of samples for laboratory analysis	4-6 52
	Bacteriological sample exceedance	4-7 53
	Fecal contamination	4-8 53
	Contamination response plan	4-9 54
	Water contamination response	4-10 55
	Pool water contamination disinfection	4-11 56
	Surface contamination cleaning and disinfection	4-12 56
	Measurement of chemical water quality	4-13 58
	Physical water quality	4-14 59
	Preopening inspections	4-15 59
	Routine inspection	4-16 59
	Aquatic facility closure	4-17 60
Section II	Health Considerations in Natural Bathing Areas	
	Diseases	4-18 61
	Water quality standards	4-19 62
	Bacteriological indicators	4-20 62
	Physical water quality	4-21 64
	Routine inspection	4-22 64
	Annual inspection/sanitary survey	4-23 64
	Cause for closure	4-24 65
Section III	Safety Considerations in Pools and Spas	
	Swimming pool drowning	4-25 66
	Swimming pool injuries	4-26 66
	Chemical hazards	4-27 67
	Source of chemicals	4-28 68
	Spa drowning and injury	4-29 68
	Water temperature of spas	4-30 69
	Supervision of swimming	4-31 69
	Lifesaving equipment	4-32 70
	Location of lifesaving equipment	4-33 70
Section IV	Safety Considerations in Natural Bathing Areas	
	Drowning and injury	4-34 71
	Guidelines for safe natural bathing areas	4-35 71
	Supervision of swimming	4-36 73
	Lifesaving equipment	4-37 73

		Page
Section V	Emergency Planning	
	Emergency planning	74
APPENDIX A	REFERENCES	77
APPENDIX B	ROLES AND FUNCTIONS FOR ADDITIONAL INSTALLATION PERSONNEL	86
APPENDIX C	SUGGESTED RULES FOR RECREATIONAL WATER FACILITIES	89
APPENDIX D	WATER QUALITY REQUIREMENTS FOR AQUATIC VENUES	92
APPENDIX E	SAFE STORAGE AND HANDLING OF CHEMICALS	94
APPENDIX F	WATER CONTAMINATION RESPONSE LOG	98
APPENDIX G	USE OF THE LANGELIER INDEX TO BALANCE POOL WATER	99
GLOSSARY		104

List of Figures

Number	Title	Page
2-1	Sprayground facility	4
2-2	Example of “No Diving” signs	11
2-3	Profile showing bottom slope, side wall, and safety ledge dimensions	13
2-4	Flume slide at aquatic facility	16
2-5	Relationship of pH, chlorine residual, and eye comfort for swimming pools	19
2-6	Basic pool chlorine chemistry	21
2-7	Breakpoint chlorination example	22
2-8	Amount of water filtered from consecutive turnovers	26
2-9	Gravity drainage system—direct suction removed from the pool	30
2-10	Suction-limiting vent system to relieve main drain suction	30
3-1	Waterfowl contamination concern	43
4-1	<i>Cryptosporidium parvum</i> oocysts	47
4-2	<i>Escherichia coli</i> bacteria	50
4-3	Measures to protect against fecal contamination	54
4-4	Enterococci bacteria	63
4-5	Common lifeguard hand signals	76
E-1	Warning sign near chlorination room	96
F-1	Sample water contamination response log	98

## List of Tables

Number	Title	Page
2-1	Relative concentration of HOCl at 86 °F	21
2-2	Required turnover rates for aquatic facilities and play features	27
4-1	Etiologic agents in recreational water-associated outbreaks (pools and spas), 2005-2010	49
4-2	Bleach solution preparation and application	57
4-3	Etiologic agents in recreational water-associated outbreaks (natural bathing areas), 2005-2010	61
4-4	Beach action values	64
D-1	Water chemistry requirements for aquatic venues	92
D-2	Bacteriological requirements for aquatic venues	93
D-3	Bacteriological requirements for natural bathing areas	93
G-1	Numerical values for Langelier formula	99

## CHAPTER 1

### INTRODUCTION

---

#### **1-1. Purpose**

*a.* Technical Bulletin, Medical (TB MED) 575 presents health and sanitation issues and associated controls and serves as a guide to Army preventive medicine/public health by—

(1) Identifying diseases associated with recreational water facilities that present a potential health concern.

(2) Describing health and safety hazards encountered and the measures necessary for the protection of personnel using recreational water facilities.

(3) Providing basic information about fundamental swimming pool and spa equipment and operations. Additional operation and maintenance information is available in Technical Manual (TM) 5-662.

(4) Outlining a surveillance program for proper operations and sanitary conditions to ensure recreational water facilities do not pose a direct threat to public health.

*b.* This bulletin is not intended to address all requirements associated with design and construction of supporting physical facilities and utilities, or fire and safety. Installation management entities, facility engineers, recreational water facility operators, and other facility support elements should use this bulletin as a guide and review the appropriate governing standards referenced in the bulletin to obtain detailed specifications.

#### **1-2. Applicability**

*a.* This bulletin applies to all recreational water facilities established and operated at Active Army, U.S. Army National Guard, U.S. Army Reserve, and Corps of Engineers (including civil works) facilities (to include lodging facilities). Privatized facilities that are not regulated or monitored by the state or local health department and are operated on an Army installation are accountable to the requirements delineated in this bulletin.

*b.* State requirements for any given recreational water facility may differ from the requirements in this document; facilities must follow the more stringent requirements.

*c.* Requirements of this bulletin apply to all existing recreational water facilities and new construction. Existing facilities found to be non-compliant for specified requirements following this bulletin's publication date may receive a waiver from the supporting preventive medicine/public health authority and installation safety office to correct areas of non-compliance until the next scheduled facility renovation. A waiver may only be granted if temporary controls can be employed to reduce potential occurrence of health and safety hazards to a low risk rating. Controls must be documented in a written procedure that is available at the recreational water facility and a copy provided to preventive medicine/public health.



### **1-3. References**

Appendix A provides a list of reference information.

### **1-4. Explanation of abbreviations and terms**

The glossary provides a list of abbreviations and terms used in this bulletin. Refer to TM 5-662 for additional definitions.

### **1-5. Preventive medicine/public health responsibilities**

*a.* Army Regulation (AR) 40-5, paragraph 1-7c, specifies that the responsibilities of installation preventive medicine/public health as related to safe and sanitary operation of Army recreational water facilities will be according to Department of the Army Pamphlet (DA Pam) 40-11, paragraph 4-4. In addition to the requirements specified in DA Pam 40-11, preventive medicine/public health will—

(1) Ensure state and/or local public health jurisdictions are aware of and have access to privatized water recreational facilities and/or public natural swim areas.

(2) Investigate any suspected or known waterborne illness outbreaks.

*b.* It is strongly recommended that preventive medicine/public health personnel involved in recreational water facility oversight maintain a certified pool operator (CPO) or aquatic facility operator (AFO) certification.

*c.* Additional installation personnel typically involved in the management and operation of swimming and bathing facilities should refer to appendix B for a listing of their major roles and functions, which may vary according to local policy. Each activity (organizations with surveillance and management oversight) at the local level should maintain a liaison with others to ensure swimming and bathing facilities operate properly.

### **1-6. Other Responsibilities**

Refer to appendix B.

## CHAPTER 2

### DESIGN STANDARDS FOR AQUATIC VENUES

---

#### Section I. Type and Location of Aquatic Venues

##### 2–1. Recirculation swimming pool with filters

*a.* A recirculation pool is an artificial structure used to impound water either above or below the ground surface with a treatment system that recirculates water to provide for such uses as bathing, swimming, diving, wading, spraying, sliding, floating, rafting, or other similar usage. All pools constructed after 1993 for Army use must be recirculation swimming pools with filters. In this particular type of swimming pool—

(1) Water is continuously withdrawn, filtered, disinfected, and returned to the swimming pool.

(2) Chemical characteristics, such as pH, which measures the hydrogen ion concentration, may be adjusted.

(3) Inlets and outlets are installed in the swimming pool shell to prevent areas of poor circulation known as “dead spots.”

*b.* Existing facilities constructed prior to 1993 must be modified to meet these requirements when undergoing substantial renovations such as re-plastering, resurfacing, or re-plumbing.

##### 2–2. Wading pools

*a.* A wading pool is intended for exclusive use by children and supervising adults. The recirculation system of a wading pool must operate independently from that of an adult pool.

*b.* The probability of infection from wading pools is greater than that from swimming or spray pools because young children are more likely than adults to contaminate and/or ingest the bathing water.

*c.* Wading pools will be—

(1) No deeper than 24 inches (measured as water depth) at the center of the pool. The bottom must have a minimum slope of not less than one-fourth inch per foot (and no more than five-eighths inch per foot) toward waste outlets or main drains.

(2) Constructed of the same material as all-purpose pools.

(3) Provided with a continuous flow of treated water to accomplish a complete change of water every 2 hours.

(4) Designed so that each outlet grate is sized to accommodate 100 percent of the recirculation flow, and the velocity through the open area of the grate is no greater than 1 foot per second. When the outlet fittings are of the anti-vortex type, maximum entrance velocities may be increased to 6 feet per second.

(5) Separated from the shallow area of adjacent swimming pools by a minimum deck width of 6 feet.

(6) Controlled so that no water is discharged into adjacent swimming pools.

(7) Provided with a minimum of two inlets and two main drains and at least one surface skimmer. Main drains will be located on the pool bottom floor and interconnected. Main drain spacing must not be greater than 20 feet or less than 3 feet on center. Each drain sump or pot must be of adequate depth and design to provide uniform suction across the entire grate area and must be anchored with corrosion-resistant screws.

(8) Provided with a mechanism for completely draining the contents of the pool to waste without passing through the filter. This may be achieved by a gravity waste line that runs directly from the pool or by pumping, thus bypassing the filter.

(9) Equipped with automatic controls to provide an adequate feed rate of disinfectant and pH adjustment chemicals. These controls apply to wading pools constructed after 2013. Automatic controls are designed to keep the disinfectant and pH at required levels on a continuous-demand basis. A warning light indicator shall be provided in a visible location for supervisory control. The device must indicate the absence of chemicals in the feeders, improper adjustment of chemical dosage, or any other mechanical or operational malfunctions (such as recirculation flow stops). Automatic chemical feeders must be wired directly to the recirculation system in order to halt the addition of chemicals when the recirculation flow stops.

(10) Designed with an open overflow, extended completely around the wading pool, that either returns the water to the wading pool filter system or drains it through an air gap to a sanitary sewer. A sufficient quantity of water must be supplied to the wading pool to accomplish the necessary turnover.

(11) Free of accessories or enhancements, such as sand, that will inhibit proper draining, harbor bacteria, or reduce the facility operator’s ability to maintain water disinfection at prescribed levels.

### 2–3. Splash pads

*a.* A splash pad, commonly referred to as a deck or wet deck, is an artificial structure used to impound water either above or below the ground surface into which treated water is sprayed and recirculated. Splash pads are primarily used by children and supervising adults. A splash pad must be independently operated (that is, its recirculation is separate from that of an adult pool). In some instances, the splash pad may be located separately, but in most cases, it is located within the swimming facility.



**Figure 2–1. Sprayground facility**

*b.* In splash pads, treated water is sprayed onto a pad and then drained or recycled into a filtration system. Unlike a wading pool, potentially contaminated water is not allowed to accumulate; therefore, a splash pad's sanitation is easier to control. Improperly designed wading pools can be converted to splash pads so they can be operated in a sanitary manner. The following criteria apply to recirculating and non-recirculating splash pads.

(1) Splash pad water must drain away freely as it sprays over the area. Water quality and wall and floor construction must meet the same requirements specified for recirculation pools. The minimum slope for the bottom of the pad shall be one-quarter of an inch per foot and shall not exceed five-eighths of an inch per foot toward waste outlets.

(2) The recirculation system must operate on a 24-hour basis and must completely turn over the entire pool volume in 1 hour or less.

(3) Splash pads must be equipped with automatic feed rate controls to keep the disinfectant and pH at required levels on a continuous-demand basis. A warning light indicator shall be provided in a visible location for supervisory control. The device must indicate the absence of chemicals in the feeders, improper adjustment of chemical dosage, or any other mechanical or operational malfunctions (such as recirculation flow stops). Automatic chemical feeders must be wired directly to the recirculation system in order to halt the addition of chemicals when the recirculation flow stops.

*c.* Water from a splash pad must not be discharged into a swimming pool.

*d.* The splash pad area shall be free of obstructions less than 4 feet in height on which children may fall or become injured; examples include raised drains, steps, or gadgets.

#### **2-4. Aquatic play features**

*a.* Water park aquatic play features (APFs) are becoming increasingly popular as interactive swimming activities. However, they present more challenges than conventional swimming pools in many respects.

(1) In general, APFs cannot be operated in the same manner as traditional pools. Many water features include special effects, such as water moving at high velocity, pulsating or surging water, or the use of pressurized air to expel water.

(2) A greater degree of automation is required to operate the various water features, creating the need for a more specialized operation and maintenance staff.

(3) The APFs have more complicated designs, can cover large areas, and tend to attract high numbers of swimmers. These factors can make it more difficult to treat, filter, and circulate the water. See the National Swimming Pool Foundation<sup>®</sup> (NSPF<sup>®</sup>) Aquatic Play Feature<sup>™</sup> Handbook. (National Swimming Pool Foundation<sup>®</sup> and NSPF<sup>®</sup> are registered trademarks of the National Swimming Pool Foundation<sup>®</sup>, Colorado Springs, Colorado; Aquatic Play Feature<sup>™</sup> is a trademark of the National Swimming Pool Foundation<sup>®</sup>, Colorado Springs, Colorado.)

*b.* A wide variety of APFs are currently being built and operated, all of which require the same levels of disinfection, but the turnover rates vary depending on the facility. Turnover is described in paragraph 2-35b. If multiple features are present in a single pool, the most conservative (that is, slowest) turnover value is applied.

(1) Wave pools, which simulate ocean swimming, generally cover large areas. This type of pool typically features a zero-depth entry that becomes progressively deeper; waves are generated periodically. The required turnover depends on the size of the APF (see table 2–3).

(2) Activity pools or play parks are usually shallow and equipped with attractions/devices, such as small slides, floats, or decorative waterfalls, which encourage physical exertion. Circulation dead spots can be a problem at these APFs. The required turnover depends on the size of the facility (see table 2–3).

(3) Catch pools are the basins of water at the end of a water slide. They are used to terminate swimmers' momentum from a slide and provide an exit to the deck or walkway area. The required turnover is 1 hour.

(4) Water slides produce the water that feeds the catch pools. The required turnover is 1 hour.

(5) Interactive play systems are water-based-play devices whose water flow volumes, pressures, or patterns are intended to be actuated by the swimmer. The water depth of these systems is generally 12 inches or less. If circulation/filtration is installed, the required turnover is 0.25 hours.

(6) Leisure Rivers are water features that mimic a natural river. Swimmers are transported (usually on flotation tubes) at a maximum current speed of 3 miles per hour throughout a loop that may include various water features or play devices. Leisure Rivers are usually at a constant depth and use pumps to provide a river-like flow.

(7) Action Rivers are water slides that mimic a mountain stream (such as rapids, whirlpools, or quiet water pools). The required turnover for these features depends on the volume of the APF (see table 2–3).

(8) Vortex™ pools are circular pools with return jets pointed in the same direction on the walls to provide a current that transports bathers around the pool. The required turnover depends on the volume of the APF (see table 2–3). (Vortex™ is a trademark of Pool Heating Distributors, Sarasota, Florida.)

## **2–5. Flow-through swimming pools**

*a.* In flow-through swimming pools, a continuous supply of fresh or chlorinated water enters at one end of the pool, and an equal amount of used water flows out the other end. Sanitary control is exercised by—

(1) Chlorinating the inflowing water.

(2) Regulating the quantity of water flowing through. Fresh water will be added at a rate of not less than 1,000 gallons per hour for each 20 bathers during that hour.

(3) Limiting the number of swimmers to 1 per 500 gallons of water or a fraction thereof.

*b.* Construction of flow-through pools after 1993 has been prohibited because control over the quality of water in such pools is very limited. Existing flow-through pools are not authorized for use unless a recirculation system meeting current requirements has been installed.

**2-6. Fill and draw swimming pools**

- a. Fill and draw pools are NOT AUTHORIZED FOR USE. These pools are filled, used until the water is dirty, then emptied and refilled with clean water.
- b. Although some fill and draw pools are equipped to provide minimal water circulation, they are not to be confused with recirculating filter pools.

**2-7. Spas**

- a. Spas are basins, chambers, or tanks of heated water designed for recreational use and physiological and psychological relaxation.
- b. Spas are—
  - (1) Made of cement, Gunitite<sup>®</sup>, tile, plastic, or fiberglass. (Gunitite<sup>®</sup> is a registered trademark of Gunitite Corporation, Rockford, Illinois.)
  - (2) Shallow in depth, not to exceed 4 feet as measured from the water line.
  - (3) Of varying sizes and capacities to accommodate one or several patrons at one time.
  - (4) Equipped with a recirculation system that includes filters, water heating devices, disinfectant feeders, and chemical feeders for pH adjustment.
  - (5) Sometimes equipped with water jets and/or blowers to provide underwater massage.
- c. Hot tubs are similar to spas, but they are usually made of wood and may not be equipped with underwater jets or bubblers.
- d. A spa or hot tub may be located in the same room or area in which a swimming pool is located but not in the same area in which a wading or spray pool is located. If the spa or hot tub is located in the same room or area as a swimming pool—
  - (1) Do not directly connect or physically attach the spa to the swimming pool.
  - (2) Do not discharge any water from the spa into the swimming pool.
  - (3) Provide a minimum of two inlets and two main drains and at least one surface skimmer. Main drains should be located on the spa bottom floor and interconnected. Main drain spacing must not be greater than 20 feet or less than three 3 feet on center. Each drain sump or pot must be of adequate depth and design to provide uniform suction across the entire grate area and must be anchored with corrosion-resistant screws.
  - (4) Provide a means of completely draining the contents of the spa or hot tub to waste without passing through the filter. This may be accomplished by a gravity waste line that runs directly from the pool or by pumping, thus bypassing the filter.
  - (5) Spas and hot tubs shall be equipped with automatic feed rate controls to keep the disinfectant and pH at required levels on a continuous-demand basis. A warning light indicator shall be provided in a visible location for supervisory control. The device must indicate the absence of chemicals in the feeders, improper adjustment of chemical dosage, or any other mechanical or operational malfunctions (such as recirculation flow stops). Automatic chemical feeders must be wired directly to the recirculation system in order to halt the addition of chemicals when the recirculation flow stops.
- e. A shower shall be installed for patrons' use prior to their entering the spa.

**2–8. Therapy pools**

*a.* Therapy pools are basins, chambers, or tanks designed for therapy or rehabilitation and are generally located at hospitals, sport therapy clinics, doctors' offices, or other medical facilities. These pools normally contain heated water and are used solely for therapy and rehabilitation purposes under the supervision of a physical therapist or other qualified medical personnel.

*b.* Higher temperatures are maintained in therapy pools to assist in rehabilitation and patron comfort. Because of this practice, stringent oversight of water quality parameters is necessary to ensure safe water conditions.

*c.* Therapy pools will be designed and constructed according to manufacturer specifications and the Unified Facilities Criteria (UFC) 4-510-01.

*d.* Therapy pools will be operated and maintained according to the Centers for Disease Control and Prevention (CDC) guidelines for controlling the spread of waterborne microorganisms in hydrotherapy tanks and pools (Guidelines for Environmental Infection Control in Health-Care Facilities). In addition, all applicable recreational water facility requirements in this bulletin, as well as manufacturer recommendations, will apply.

**Section II: Design and Construction Details****2–9. General**

*a.* The garrison commander, through the public works activity, is responsible for preparing and submitting construction documents in accordance with military and local regulations. Documents must be approved by a local or higher jurisdictional public health agency.

*b.* The medical commander and/or a preventive medicine/public health representative and the installation safety officer will review all concept designs and final plans for construction of swimming pools and spas with regard to sanitary control and safety prior to final acceptance of the plans and authorization for construction. The design and construction details presented in the remainder of this chapter are intended to—

(1) Provide guidance for design review of proposed new facilities.

(2) Point out possible deficiencies that should be addressed either on an immediate basis or deferred until the next scheduled upgrade, as the seriousness of the deficiency dictates.

*c.* Water park facilities must meet design and construction standards found in American Society for Testing and Materials (ASTM) F1159-11, current industry standards, and manufacturer recommendations.

*d.* Competitive swimming or diving facilities will be constructed according to requirements and/or applicable Federation Internationale de Natation (FINA) Handbook 2009 – 2013 standards.

*e.* Department of Defense (DOD) facilities are currently directed to comply with the Americans with Disabilities Act (ADA) Accessibility Guidelines for Buildings and Facilities, Architectural Barriers Act (ABA) Accessibility Guidelines (69 Federal Register (FR) 44084) adopted by DOD in 2008.

*f.* Recirculating pools, spas, and other facilities must meet American National Standards Institute (ANSI)/National Spa and Pool Institute (NSPI)-1 current industry standards and manufacturer's recommendations. (Note: The NSPI became the Association of Pool and Spa Professionals® (APSP®) in 2007. The ANSI/NSPI-1 standard is also known as ANSI/APSP-1.) (Association of Pool and Spa Professionals® and APSP® are registered trademarks of the Association of Pool and Spa Professionals Corporation, Alexandria, Virginia.)

*g.* The creation of new recreational water features is ongoing; therefore, all such features cannot be specifically mentioned in this document. To ensure patron safety, always follow the manufacturer's specifications and guidance.

*h.* Refer to the CDC's Model Aquatic Health Code (MAHC) to obtain information regarding design, construction, operation, and maintenance of recreational water facilities not addressed in this bulletin.

## **2-10. New construction pre-opening inspection**

*a.* Approximately 30 days before opening, representatives of preventive medicine/public health, the directorate of public works (DPW), the installation safety office, and directorate of family, morale, welfare and recreation (DFMWR) will perform a pre-opening inspection of newly constructed recreational water facilities.

*b.* The purpose of this inspection is to determine compliance with this bulletin and to ensure that procedures are established to provide for the effective sanitary control and safety of the facility. This inspection is not a substitute for the proper sanitary design and construction of a facility, nor is it intended to take the place of competent design review. The sole purpose of this inspection is to identify areas that were overlooked during construction. The facility will not open until the noted deficiencies have been corrected.

## **2-11. Designated areas**

*a. Instructional areas.* The areas of a swimming pool used primarily for instruction should be visually set apart from the rest of the pool by a lifeline and a permanent, non-slip black or dark-colored tile stripe, between 4 and 6 inches in width, incorporated in the floor and the wall of the pool.

*b. Shallow areas.* The shallow area of the swimming pool is delineated from the 3-foot depth marker to a pool depth of 5 feet 6 inches. The shallow area should be visually set apart from the rest of the pool. A lifeline shall extend across the pool between the shallow and deep ends and be positioned 1 to 2 feet on the shallow side of the transition point where the depth exceeds 5 feet 6 inches. Where there is no transition point, the lifeline must be placed at the 4-foot 6-inch depth marking. The pool must have a uniform slope from the shallow end to the slope of the transition point, and the slope must not exceed 1 foot vertical to 10 feet horizontal in the same manner as the instructional areas.

## **2-12. Bather load**

*a.* The bather load (the number of swimmers allowed in the water) must be determined for every swimming pool or spa. The building occupant load (the total number of persons that might



occupy the facility or a portion thereof) is determined by the fire department that services the facility. Bather load and building occupant load shall be posted in an area that is visible upon entrance to the pool area and in staff areas of the operation.

b. Bather load shall be based on square footage of surface water or, if no standing water is present, the surface area of an aquatic venue. Bather load for all aquatic venues shall be calculated as—

(1) *Flat water*: 20 square feet (sq ft) per bather. This calculation includes water slides (runout area and exposed water as equivalent surface water), plunge pools, and aquatic venues without standing water (calculate the perimeter deck area for bather load).

(2) *Agitated water*: 15 sq ft per bather.

(3) *Hot water*: 10 sq ft per bather.

## 2-13. Materials

a. Construct swimming pools and accessories using materials that—

(1) Are inert, nontoxic to humans, impervious, and designed to handle environmental conditions (for example, ultraviolet rays, corrosion, humidity, and freezing/thawing) and the use of strong disinfectants throughout the useful life of the facility, equipment and/or accessories.

(2) Can withstand design stresses.

b. The swimming pool should have a watertight tank with a smooth and easily cleanable surface, or the tank should consist of a material to which a cleanable surface finish has been applied. If a pool structure is lined with a dissimilar material, the two materials must be continually and permanently bonded so as not to separate at any time or place.

c. Finish the swimming pool in white or light colors; the material should have greater than 55 percent reflectance value. This finish will be smooth, without cracks or joints, with the exception of structural expansion joints. Tiles, if smooth, are permissible on pool sides and bottom. Earth or sand pool bottoms are not permitted.

d. All pools with depths exceeding 18 inches must have at least one hydrostatic pressure relief valve (or other hydrostatic relief system) installed.

e. A minimum 6-inch glazed, frost-proof tile or other easily cleanable surface must be placed at the normal water line.

## 2-14. Markings

a. Ensure markings and numerals are—

(1) A minimum of 4 inches in height.

(2) Colored to contrast with the pool sides and deck.

(3) Placed at intervals no greater than 25 feet.

(4) Plainly visible to persons in the swimming pool and on the deck.

b. Consider the effects of sunlight and glare in determining the proper position and color selection.

c. Plainly mark the water depth at or above the water surface in two places:

(1) On the vertical pool wall.

(2) At the edge of the deck next to the pool. If depth markers cannot be placed on the vertical walls of the pool above the water level, use other means of display such as signs on the walls. Also mark points of maximum and minimum depth, points of break between deep and shallow portions, and intermediate increments of water depth at increments of no more than 2 feet.

*d.* In areas where the water is 5 feet or less in depth, “No Diving” warning signs and the international symbol for “No Diving” illustrated in Figure 2–2 shall be placed at intervals of no more than 25 feet (7.6 meters) around the pool perimeter on the adjacent horizontal surface or pool deck (coping).



**Figure 2–2. Examples of “No Diving” signs**

*e.* All signs, except those on the adjacent horizontal surface or coping, should have letters of at least 4 inches in height that are colored to contrast with the background.

*f.* Children’s activity pools that are part of a larger pool must be clearly distinguished from pool areas with water depths greater than 24 inches. Distinguishing markings shall include a dark, nonslip tile transition line of high-contrasting color located on the bottom of the pool and extending along the entire 2-foot water depth contour. The minimum width of the transition line shall be 2 inches.

*g.* For competition pools, according to recommendations from USA Swimming, flush, non-slip targets shaped as a “T” or a cross and having the same width as lane bottom markers shall be provided in the center of each lane on the end wall of the course. Targets shall extend at least 3 feet 4 inches (1.0 meter) below the level of the water surface. It is recommended that the top edge of the deck be of a contrasting color to provide a visual target above water at the end of the course.

**2-15. Water supply**

*a.* The water supply serving all swimming pools, spas, and plumbing fixtures, including drinking fountains, lavatories, toilets, and showers, shall meet all Federal, state, and local applicable requirements for potable water. Submit requests to use alternate water sources, including saline or brackish water, for swimming pools or spas through the major Army command to The Surgeon General (TSG), Headquarters, Department of the Army (HQDA), Directorate of Health and Wellness (DASG-PPM-NR), Falls Church, VA 22041-3258.

*b.* Cross-connections are not permitted. Protect all portions of the water distribution system serving recreational water facilities and their auxiliary facilities against backflow.

*c.* Water introduced to a swimming pool or spa, either directly or through the circulation system, shall be supplied through one of the following configurations or its equivalent, to protect the public water supply:

(1) An air-gap which is 2 times the diameter of the water supply outlet or pipe (American Society of Mechanical Engineers (ASME<sup>®</sup>) A112.1.2). (ASME<sup>®</sup> is a registered trademark of the American Society of Mechanical Engineers.)

(2) A pipe-applied atmospheric vacuum breaker installed at least 6 inches above the highest downstream outlet and downstream of all valves and pumps (ANSI/American Society of Sanitary Engineers (ASSE) 1001).

(3) A pressure type anti-siphon vacuum breaker installed at least 12 inches above the highest downstream outlet (ANSI/ASSE 1020).

(4) A reduced-pressure-principle backflow preventer (ANSI/ASSE 1013; American Water Works Association<sup>SM</sup> (AWWA) C511-07). (American Water Works Association<sup>SM</sup> is a service mark of the American Water Works Association, Inc., Denver, Colorado.)

*d.* Whenever an over-the-rim spout is used to introduce water into a pool or spa, shield it so it does not create a hazard by locating it adjacent to a ladder or under a handrail.

(1) If the pool is equipped with a diving board, locate the over-the-rim spout under the diving board.

(2) The open end of the spout will—

*(a)* Have no sharp edges.

*(b)* Protrude no more than 2 inches (preferably not more than 1 inch) beyond the edge of the pool or spa.

*(c)* Be located above the rim of the swimming pool at a height of at least two diameters of the fill spout or at an above-the-rim supply to the surge tank, whereby no arrangements exist which would, under any condition, permit contaminated water to re-enter the potable water system.

**2-16. Accessible means of entry**

Swimming pools, spas, catch pools, wading pools, and specialty pools where user access is limited to one area, such as wave action pools and leisure rivers, must meet ABA requirements.

**2-17. Bottom slope, side walls, and safety ledges**

a. Construct the bottom slope, as illustrated in figure 2-3, so that it is uniform and does not exceed—

- (1) One foot over a distance of 12 feet for the area of the pool with a depth less than 5 feet.
- (2) One foot over a distance of 3 feet for the area of the pool with a depth greater than 5 feet.

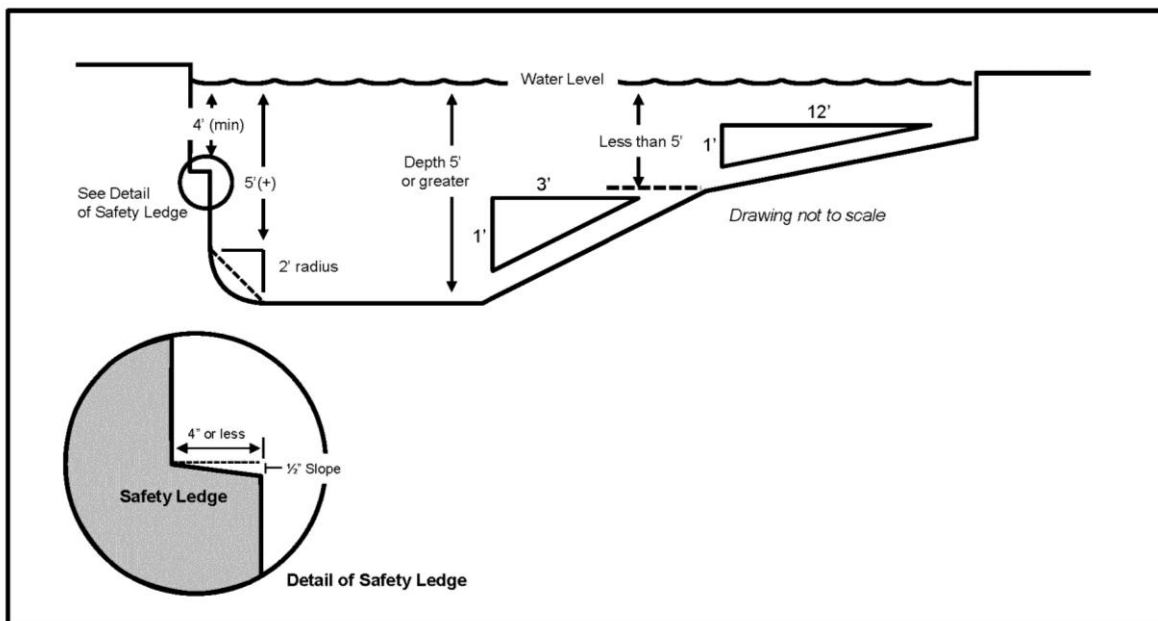

**Figure 2-3. Profile showing bottom slope, side wall, and safety ledge dimensions**

b. Construct the pool walls so that they are vertical to the depth of at least 5 feet below the water level and then curved to the bottom with a radius not greater than 2 feet. The arc of the radius will be tangent to the wall. Walls may be sloped to the bottom instead of curved, provided the sloped area does not intersect the area formed by a curve with a 2-foot radius.

c. Safety ledges, when provided on vertical walls in deep portions of the pool, will—

- (1) Be of a contrasting color.
- (2) Not be wider than 4 inches.
- (3) Be at least 4 feet below the water surface.
- (4) Slope 1/2 inch across the width of the ledge toward the center of the pool.

**2-18. Steps and ladders**

a. Provide steps or ladders at the shallow end of a swimming pool. As a minimum, provide a means of exit for every 75 linear feet of pool wall. Provide ladders or recessed steps, one on each side, at the deep end of the swimming pool.

(1) Ensure steps leading into pools are of a nonslip design and have a minimum tread width of 12 inches and a maximum rise of 10 inches.

(2) Equip corrosion-resistant ladders with nonslip treads. Provide handholds and securely install them with a clearance of not more than 5 inches and not less than 3 inches between the ladder and pool wall.

*b.* If steps are inserted in the walls, or if step holes are provided, ensure that they are easily cleanable and arranged to drain into the pool to prevent the accumulation of dirt. Step holes must have a minimum width of 14 inches.

*c.* Where steps, step holes, or ladders are located within the pool, provide a handrail at the top of both sides extending over the edge of the deck. Handrails and ladders shall be kept firmly secured to the deck and maintained in good repair. Locate steps and ladders where they will not interfere with racing lanes, if applicable. Install ladder bumpers as required.

*d.* Stairs must be recessed in pool areas where lap swimming or wave action occurs.

*e.* Ensure that the platform or diving board steps are corrosion-resistant, easily cleanable, and of a nonslip design.

*f.* Provide handrails at all steps and ladders leading to diving boards. Equip all platforms and diving boards with guardrails. The back and sides of each platform must be surrounded by guardrails, and 3-meter diving boards must have guardrails extending at least to the pool edge to prevent divers from falling onto the deck.

*g.* Additional protective measures may be necessary to prevent falls around diving boards and should be evaluated on a case-by-case basis.

## **2-19. Connections for safety lines**

Recess all connections for safety lines, lane markers, and similar fittings in the walls at appropriate locations and in a manner that presents no hazards to persons using the pool.

## **2-20. Decks and adjacent areas**

*a.* Construct the pool deck according to the requirements of ANSI/APSP-1.

*b.* Ensure the surface of the paved walk or deck is a nonslip surface, is kept clean and free of puddles, and does not drain into the swimming pool or the overflow gutter. To prevent muddy, hazardous, or objectionable conditions, direct the drainage away from the pool area. If deck drains are provided, they will—

(1) Have an inlet opening of at least 4 inches in diameter.

(2) Be spaced and arranged so that not more than 100 square feet of area is tributary to each drain.

(3) Not be spaced more than 25 feet apart.

*c.* Completely fence the swimming pool area so that the only entrance and non-emergency exit to the pool are made via the bathhouse.

*d.* At outdoor pools, fence off the unpaved areas accessible to swimmers, and install a shower for swimmers to use prior to their reentry to the paved area of the pool.

*e.* Cracks in the pool decks will be repaired when determined to be a potential cause of leakage, a safety/tripping hazard, or a hygiene hazard. (Clean, sharp, irregular edges are difficult to clean adequately.)

## **2–21. Diving areas**

*a.* Diving equipment should be kept firmly secured to the deck and maintained in good repair. For stability under the greatest possible load, install diving platforms, jump stands, and springboard supports that are rigidly constructed and properly anchored. These areas must also have a nonslip surface.

*b.* When instructional or supervised diving is not in progress, the diving board fulcrum should stay in the forward position, with the area roped off and signs posted prohibiting patron use.

*c.* Pools with diving equipment of 3 meters or greater in height, or pools designed for springboard or platform diving, will comply with the dimensional design requirements of the FINA Handbook 2009 – 2013 or the appropriate sanctioning body.

*d.* Diving equipment at pools intended for public recreational swimming (that is, pools not intended for use in competitive aquatic events) must be installed according to ANSI/APSP-1.

*e.* The use of starting blocks is prohibited except during competitive swimming or swimmer-related activities. Starting blocks should be equipped with protective equipment designed to prevent access, such as roping off the area around the blocks and posting signs prohibiting their use in non-competition activities. When the starting blocks are removed, the anchor sockets must be capped. Starting blocks—

- (1) Will be firmly secured when in use.
- (2) Will have nonslip top surfaces.

## **2–22. Swimming pool slides and flumes**

If not properly constructed, located, and used, slides can be very dangerous appurtenances at any swimming pool.

*a.* Swimming pool slides (non-flume slides), which are similar in construction to playground slides, allow users to slide into a pool from an elevated height. They will be designed and constructed according to Consumer Product Safety Act (15 U.S. Code (USC), Sections 2051–2089) (Public Law 92-573; 86 Stat. 1207, October 27, 1972), ASTM, and manufacturer specifications.

*b.* Slides will be installed and used according to the manufacturer’s instructions.

*c.* Pool slides shall—

- (1) Have a flow rate of less than 100 gallons per minute (gpm).
- (2) Meet the specifications of 16 CFR 1207.5.
- (3) Terminate at or below the normal operating water level in the pool (except for drop slides).

*d.* Water depth at the slide terminus shall be maintained as specified by the slide manufacturer.

- e. The terminus end of the slide will be protected through the use of a float line, wing wall, or other similar impediment to prevent collisions with pool patrons.
- f. Slides will be kept firmly secured to the deck and maintained in good repair.
- g. Entry access points will be controlled such that unauthorized entrance is not permitted.
- h. The use of pool slides will be monitored for safe operation and proper maintenance.

Appendix C provides suggested rules specific to the use of pool slides.

i. Slides will be monitored and inspected according to manufacturer specifications. Inspection/maintenance checklists must be kept onsite. Questions concerning the proper maintenance of pool slides should be directed to the manufacturer.

j. Flume slides are slides of various configurations that are characterized by deep riding channels, vertical and lateral curves, and high water flows; they can accommodate patrons using mats, tubes, rafts, and other water transport vehicles. Flume slides must comply with provisions of the CDC MAHC section 4.12.2, “Water Slides and Catch Pools.”

k. Some slides and flumes have their own suction and wall covers to pump water to the top of the slide or flume. These covers and mechanisms must comply with the Virginia Graeme Baker Pool and Spa Safety Act, hereinafter referred to as the VGB Act (15 USC 8001) (see paragraph 2–38).



**Figure 2–4. Flume slide at aquatic facility**

### **Section III: Disinfection**

#### **2–23. Types of disinfectants**

- a. Although a number of disinfectants are available for the treatment of pool water, including chlorine, bromine, ozone, and others, chlorine and chlorine compounds are used most

frequently due to their availability, high degree of effectiveness, ease of measuring residuals, relative ease in handling, and economy.

*b.* If the use of an alternative disinfectant (that is, other than chlorine or bromine) is desired, requests for its approval shall be routed to TSG as described in paragraph 2–15*a* of this bulletin. If an alternate disinfectant is to be used only as supplemental oxidation, TSG approval is not required.

(1) Requests for approval of alternate disinfectants are necessary due to the possibility of toxic effects occurring and because of the variations in their application and testing procedures. Consider these factors with regard to equipment and manpower capabilities.

(2) The use of alternative disinfectants will be evaluated on a case-by-case basis.

## **2–24. Disinfection of aquatic venue water**

*a.* Disinfect aquatic venue water by maintaining a bactericidal concentration of a residual disinfectant, such as chlorine, throughout the facility.

*b.* Due to the complexity of water park facilities and their tendency to create water aerosols, the use of a secondary disinfection method at these facilities is recommended.

*c.* In recirculation-type pools (including recirculation-type wading and spray pools), add the required concentration of disinfectant solution to the recirculated water.

*d.* In flow-through pools, add the chemical to the inlet water.

*e.* Essential equipment required for disinfection includes—

(1) Pump(s).

(2) A disinfection unit (chlorinator, for example).

(3) An outlet system to bring water from the pool for disinfection.

(4) An inlet system to distribute the disinfected water uniformly throughout the pool.

*f.* Disinfection system components will be National Sanitation Foundation (NSF<sup>®</sup>)-certified. (NSF<sup>®</sup> is a registered trademark of NSF International, Ann Arbor, Michigan.)

(1) NSF International is an independent testing agency that maintains a searchable listing of pool and spa equipment approved under NSF/ANSI Standard 50. The listing of NSF-certified equipment is available at [http://www.nsf.org/certified/consumer/listings\\_main.asp](http://www.nsf.org/certified/consumer/listings_main.asp).

(2) The NSF International Mark affixed to the equipment indicates compliance with the standards of that organization.

*g.* Automatic disinfection equipment will be used on kiddie pools, spray pools, wading pools, hot tubs, and spas to ensure disinfection residuals are maintained within proper ranges. Although not required, automatic disinfection equipment may be used for larger bodies of water such as recirculation pools, wave pools, Leisure Rivers, and water parks. The installation and use of chemical feeders shall conform to the following:

(1) Disinfectant residual levels and pH are monitored and controlled automatically by suitable devices measuring the oxidation-reduction potential (ORP).

(2) A continuous and effective residual of disinfectant within the water is provided 24 hours a day.

(3) The design feed rate provides effective disinfection levels in peak demand conditions.



(4) The feeder is capable of applying a dose equivalent capable of maintaining a concentration of at least one milligram per liter (mg/L) of free available chlorine (FAC) throughout the water during pool operating hours.

(5) Chemical feed and control systems are installed and maintained according to the manufacturer's specifications.

(6) Chemical feed systems are designed so they cannot operate unless there is return flow to properly disburse the chemical throughout the pool. Systems are installed with direct wiring to the recirculation pump to halt chemical addition when the recirculation flow stops.

*h.* The method of chemical addition must protect the swimmers from contact with concentrated chemicals and must provide adequate distribution of the chemical throughout the pool.

*i.* Optimum disinfectant concentrations—

(1) Provide rapid destruction of all potential pathogenic microorganisms (such as bacteria, cysts, fungi, viruses, protozoa).

(2) Control algae.

(3) Provide continual oxidation of organic impurities and ammonia nitrogen fractions.

(4) Do not cause eye irritation (see figure 2–5).

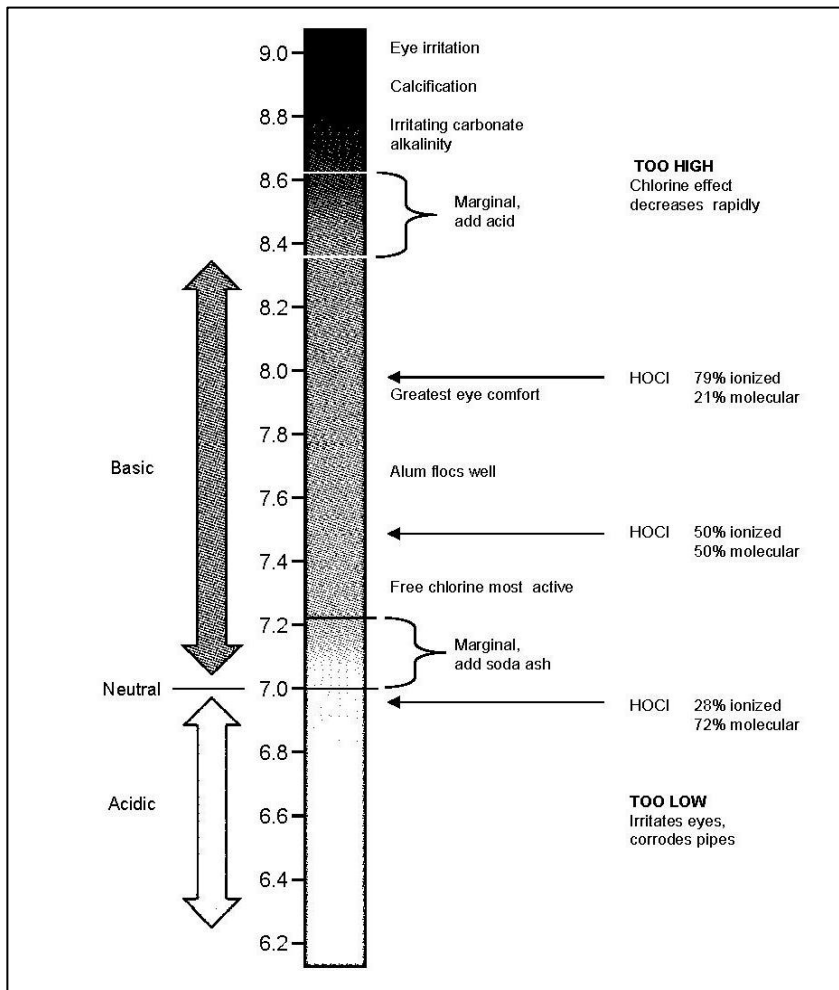

Figure 2-5. Relationship of pH, chlorine residual, and eye comfort for swimming pools

(5) Are maintained at an adequate measurable residual to ensure continuing disinfection and algae control in the swimming pool.

(6) Reduce the danger of disinfection byproducts (DBPs) and chemical off-gassing.

j. Hand-feeding of chemicals is not permitted during hours of operation or 30 minutes prior to opening.

**2–25. Oxidation reduction potential**

a. All automated feed systems must have an ORP sensor to ensure proper balance is maintained and chemicals are not added unnecessarily.

b. The ORP measures the effectiveness of the disinfectant as an oxidizer. An increase in the concentration of oxidizers results in an increase in the ORP reading.

c. The ORP shall be maintained within proper ranges with a minimum reading no less than 650 millivolts.

(1) Measurements of the ORP must be taken in conjunction with routine monitoring of the FAC residual.

(2) A drop in ORP readings may indicate that a corresponding drop in the disinfectant residual or a significant increase in pH has occurred.

(3) If pH and disinfectant residuals are continuously analyzed and controlled in pools, disinfection residuals may be maintained at a higher level (up to 5 mg/L) to maintain proper ORP levels.

(4) If pH and disinfectant residuals are continuously analyzed and controlled in spas, disinfection residuals may be maintained at a higher level (up to 10 mg/L) to maintain proper ORP levels.

d. Oxidation reduction potential systems have two probes, one for chlorine and one for pH.

(1) The control unit uses readings from the probes to operate chemical feeder pumps, which maintain chlorine and pH within acceptable limits.

(2) Probes are installed in the pressure line, or water may be diverted to the probes from the pressure line. The probe must be installed at a point prior to chemical injection.

e. The electrodes in the flow cell need to be cleaned and calibrated regularly in order for the controller to operate properly. Follow the directions in the owner’s manual. Some ORP units may be monitored remotely; they alert the pool operator to make a service call when needed. If the controller does not alert operators remotely (such as an alarm sounding in the pump room or a notification sent to the operator’s station), lifeguards must record the ORP levels when they record the disinfectant and pH levels.

**2–26. Disinfection using chlorine**

a. A number of factors affect the bactericidal action of chlorine in swimming pool water. Among these are the pH of the water and the FAC residual.

(1) When chlorine is added to water, hypochlorous acid (HOCl) and hypochlorite ions are produced. Hypochlorous acid is the compound that kills or inactivates pathogens and algae and oxidizes bather wastes. The pH of the water is an extremely important factor in determining the effectiveness of the HOCl (table 2–1). In general, as the pH rises, the HOCl becomes less

effective. It is also important to note that the mucous membranes of the eyes, nose, and throat are least affected by residual chlorine when the pH is 7.4.

(2) Further explanation of chlorine chemistry is provided in TM 5–662.

**Table 2–1. Relative concentration of HOCl at 86 degrees Fahrenheit (°F)**

pH	% Active HOCl
6.0	97
6.5	91
7.0	76
7.2	66
7.5	50
7.8	33
8.0	24

c. The minimum allowable FAC for aquatic venues is 1 mg/L and 3 mg/L, respectively. When cyanuric acid is used in pools, the minimum allowable FAC shall be 2 mg/L. Appendix D details the requirements for proper pool chemistry.

d. For those facilities using elemental chlorine in the compressed gaseous form—

(1) The chlorinator shall have an emergency cut-off device to prevent a gas discharge or an injection of gas during an electrical outage. A gas chlorine detection device with an alarm must also be provided.

(2) The guidance provided in appendix E on safety precautions for chlorination facilities shall be followed. TM 5–662 provides detailed instructions on gas chlorination equipment.

e. Due to safety and security concerns, gas chlorination may not be installed in facilities constructed after 2013. Facilities constructed prior to 2013 that are equipped with gas chlorination are strongly encouraged to consider an alternate form of chlorination.

f. When chlorine is added to water containing nitrogenous substances (such as ammonia, urine, and perspiration), the chlorine may combine with these substances to form chloramines. Chloramines are only 1/50 to 1/100 as effective as FAC. Figure 2–6 illustrates basic pool chlorine chemistry.

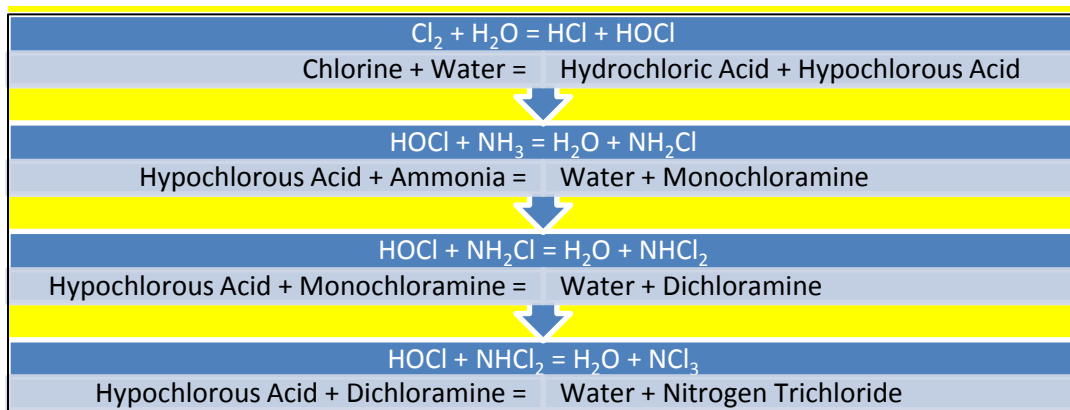

**Figure 2–6. Basic pool chlorine chemistry**

*g.* The potable water supplies at some Army facilities are disinfected with chloramines. A portion of the chloramines will be consumed by the routine addition of free chlorine. However, a certain level of the chloramines may remain in the pool water. A chloramine level above 0.4 mg/L can result in odors and eye irritation and should be avoided. The chloramine level, also referred to as combined available chlorine (CAC), is calculated by subtracting the FAC from the total available chlorine (TAC) in the water; figure 2–7 provides an example. Practicing breakpoint chlorination, that is, raising the FAC level to 10 times the measured chloramine level, will eliminate chloramines. This procedure may be used at all pools, spas, and APFs where the chloramine level exceeds 0.4 mg/L.

<p><b><u>FORMULA</u></b></p> <p><b>TAC (mg/L) – FAC (mg/L) = CAC (mg/L)</b></p> <p><b>CAC (mg/L) x 10 = FAC necessary to reach breakpoint</b></p>
<p><b><u>EXAMPLE</u></b></p> <p><b>2 mg/L – 1.5 mg/L = 0.5 mg/L</b> CAC above 0.4 mg/L must be eliminated/reduced</p> <p><b>0.5 mg/L x 10 = 5 mg/L</b> FAC must be raised to 5 mg/L to reach breakpoint</p>

**Figure 2–7. Breakpoint chlorination example**

- h.* Breakpoint chlorination should be implemented outside of normal pool operating hours due to the potential for respiratory irritation from gasses released during the process.
- i.* When breakpoint chlorination is achieved, the large amount of chlorine added to the pool water should be used up in the process. Free chlorine levels will return to normal operating levels, and chloramines will be eliminated. Pool staff must verify that the free chlorine is at the appropriate level before allowing swimmers into the pool.
- j.* Alternate technologies, such as granular activated carbon filters or ultraviolet (UV) light, may be used to reduce chloramine levels. The pool/spa must continue to meet all applicable water quality standards (such as chlorine residual) when alternate chloramine reduction technologies are employed.

## **2–27. Electrolytic chlorine generators**

*a.* Electrolytic chlorine generators (ECGs) are often referred to as “salt water pools.” The four components of an ECG are the power supply, the electrolytic cell, a flow-protection device, and sodium chloride (salt), which is dissolved in the pool water. Salt is added to the water and passed through an electrolytic cell, producing chlorine gas, sodium hydroxide, and hydrogen gas.

*b.* Salt is added to the pool/spa at a concentration of 3,000 mg/L, which is approximately 7 percent of the salt level in sea water. During the electrolytic process, the salt continuously recycles itself so it is only necessary to add more salt approximately twice a year to replace the loss from bather carry-off, splash-outs, overflows, and filter backwashing maintenance.

*c.* The ECGs can reduce the quantity of chemicals required to be maintained onsite. However, an additional cost is incurred from continuously running the electrodes at several hundred watts whenever the pool pump is on.

*d.* Since pools using onsite chlorine generators are generally no different from conventionally chlorinated pools, the required disinfectant residuals and chemical testing are the same for both. However, the chloride levels of ECG-equipped pools must be monitored to determine if additional salt should be added. Salt levels shall be checked at least weekly or more frequently, per manufacturer instructions.

*e.* Maintenance of an ECG will include cleaning the electrode plates according to manufacturer specifications and periodically replacing them (the frequency depends on the water quality).

## **2–28. Cyanuric acid**

*a.* Because chlorine residuals are depleted very quickly in the presence of sunlight, it is difficult to maintain proper levels of disinfectant in outdoor pools. Cyanuric acid may be added to swimming pools to stabilize the chlorine residual or may be added in the form of chlorine that is already stabilized: dichloroisocyanuric acid (“dichlor”) or trichloroisocyanuric acid (“trichlor”).

*b.* The use of cyanuric acid has been found to reduce the effectiveness of HOCl as a disinfectant. Although this drop in effectiveness is not apparent in FAC monitoring, it is apparent in ORP readings. The ORP will drop as the cyanuric acid levels in the pool increase.

*c.* When cyanuric acid is used in pools, a minimum chlorine residual of 2 mg/L is required. Although it has recently been suggested that higher chlorine residuals be maintained when cyanuric acid is used, research has not yet clearly shown that this practice is appropriate for “real world” use.

*d.* Ideally, a cyanuric acid concentration no higher than 30 mg/L should be maintained to stabilize the FAC against the destructive action of sunlight; concentrations must never be greater than or equal to 50 mg/L.

*e.* Cyanuric acid or stabilized chlorines may not be used in spas or indoor pools.

## **2–29. Disinfection using bromine**

*a.* Bromine is effective for disinfection of indoor pools and spas that are not exposed to direct sunlight. Bromine is rapidly displaced when exposed to sunlight and is ineffective for use at outdoor recreational water facilities.

*b.* When bromine is used as a disinfectant—

(1) Feed the bromine continuously.

(2) Maintain a concentration of at least 3 mg/L bromine residual throughout the pool water at all times. The bromine residual shall not exceed 4 mg/L at any time during pool use.

- (3) Maintain a concentration of at least 6 mg/L bromine residual in spas.
- (4) Use solid-stick or tablet-type bromine and NSF-certified feed equipment. A listing of NSF-certified equipment is available at the following NSF International Web site:  
[http://www.nsf.org/certified/consumer/listings\\_main.asp](http://www.nsf.org/certified/consumer/listings_main.asp).
- (5) Do not use bromine in conjunction with ozone or cyanuric acid.

### **2–30. Ozone disinfection**

- a. Ozone disinfection.* Ozone is a powerful oxidizer and disinfectant that can effectively inactivate bacteria, viruses, and chlorine-resistant protozoa such as *Cryptosporidium* and *Giardia*. An added benefit of ozone use is that it aids in the destruction of chloramines.
- b.* Ozone may only be used as a supplemental oxidizer since it does not provide a lasting residual in the water. Therefore, a chlorine-based disinfectant is still required.
- c.* Ozone must be properly applied according to manufacturer specifications. At low concentrations, ozone is an irritant to swimmers, and it becomes toxic at higher concentrations. It is heavier than air and presents a risk of becoming concentrated at the surface of the water.
- d.* The Occupational Safety and Health Administration (OSHA) limit for ozone is a maximum of 0.1 mg/L in an 8-hour exposure. To ensure this limit is not exceeded, ozone systems are designed to apply the ozone in the recirculation system at a point before the circulation water is returned to the pool.
- e.* Ozone systems must be installed and used according to NSF/ANSI Standard 50.

### **2–31. Ultraviolet disinfection**

- a.* New studies suggest UV treatment devices can reduce chloramine levels as well as effectively inactivate pathogens (including *Cryptosporidium*).
- b.* Since a UV treatment does not provide a disinfectant residual, it may only be used as a supplemental oxidizer in conjunction with a traditional disinfectant. Therefore, a chlorine or bromine-based disinfectant is still required.
- c.* Ultraviolet light has no effect on pH or color and has little effect on the chemical composition of the water. The color, turbidity, and chemical composition of water can, however, interfere with UV light transmission. Inactivation of microorganisms is dependent upon many factors, such as UV dosage, water quality, and contact time (flow rate through the device).
- d.* Ultraviolet lamps must be installed according to manufacturer specifications at a point after the filters and prior to chemical injection.
  - (1) Ensure UV lamps are installed with a service bypass line and will treat the full flow of water from the filters.
  - (2) Maintain UV systems according to manufacturer specifications to prevent loss of effectiveness.
- e.* Ultraviolet systems must be installed and used according to NSF/ANSI Standard 50.

### **2–32. Disinfection using ion-generating devices**

- a.* Copper/silver ionizers are electrical devices that release measured amounts of silver and copper ions into the pool or spa water.

*b.* Although silver ions inactivate bacteria, and copper ions are an effective algaecide, copper/silver ionizers are incapable of oxidizing bather organics. A sanitizer such as chlorine must be used to provide complete disinfection and oxidation. Residuals of at least 0.4 mg/L chlorine or 0.8 mg/L bromine must be provided as a supplementary sanitizer/oxidizer.

*c.* There is an increased probability of staining pool surfaces if the concentration of copper ion in pool water exceeds the manufacturer's recommended maximum.

*d.* Periodic testing is necessary to check and maintain the recommended ion concentrations. Copper test kits are normally supplied by the ionizer manufacturer. Silver ion concentrations are usually estimated by applying a conversion factor to measured copper.

### **2–33. Prohibited disinfection practices**

- a.* Ultraviolet/hydrogen peroxide systems are prohibited for use as a disinfectant.
- b.* Polyhexamethylene biguanide hydrochloride is prohibited for use as a disinfectant.
- c.* Chlorine dioxide is not permitted for use while swimmers are in the water.

## **Section IV: Recirculation**

### **2–34. General**

When multiple aquatic venues are located within the same aquatic facility, each venue must be designed to have its own independent recirculation system. For example, a pool requires a circulation, filtration, and disinfection system that is separate from a spa's system. Provisions for adequate treatment and recirculation of the water at each aquatic venue are required. Existing aquatic facilities should be modified to meet these requirements when substantial renovations such as replastering, resurfacing, or replumbing occur.

### **2–35. Recirculation system appurtenances**

*a.* Recirculation systems consist of pumps, pipes, filters, and water conditioning and disinfection equipment. Components must be NSF-certified and shall be operated continuously. A listing of NSF-certified equipment is available at the following NSF International Web site: [http://www.nsf.org/certified/consumer/listings\\_main.asp](http://www.nsf.org/certified/consumer/listings_main.asp).

*b.* Turnover is the length of time necessary for the pool's circulation system to handle as many gallons as the pool holds. The processes of filtration and chemical treatment occur during circulation before water is returned to the pool; however, only a fraction of the circulated water is actually filtered during each turnover.

(1) During the recirculation process, turbid (dirty) water is continuously withdrawn and replaced by filtered water. Specifically, each succeeding portion of withdrawn water consists of a decreasing proportion of turbid water mixed with an increasing proportion of clean water. This process, repeated enough times, helps reduce turbidity levels and achieve specified water quality standards. Figure 2–8 depicts the amount (percentage) of water that has been filtered after consecutive turnovers have occurred. It is only after four consecutive turnovers (the minimum



required number of turnovers in a 24-hour period) that the amount of unfiltered water is reduced to two percent.

(2) Turnover time is calculated by dividing the total volume of water by the flow rate through the filtration process. The maximum required turnover time varies based on the type of aquatic facility and play feature and the volume of water sustained by the venue (table 2–2).

c. The turnover rate represents the number of turnovers that occur over a 24-hour period.

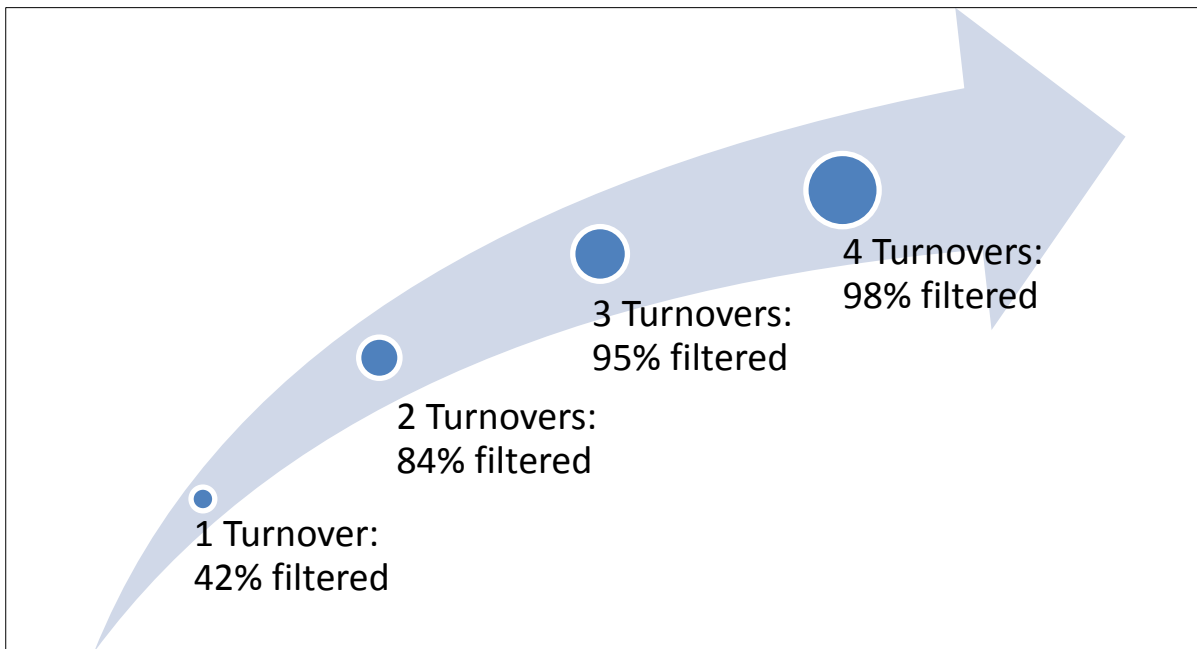

**Figure 2–8. Amount (%) of water filtered from consecutive turnovers**

**Table 2–2. Required turnover times for aquatic facilities and play features**

Facility	Volume (Gallons)	Maximum Turnover Time (Hours)
Swimming pool	<200,000	4
	≥200,000	5
Wading pool	ALL	0.5
Spa	<10,000	0.25
	≥10,000	0.5
Therapy pool	ALL	0.5
Catch/plunge pool	ALL	1
Water slide	ALL	1
Spray pad	ALL	0.17
Action river; vortex pool	<100,000	1
	≥100,000	1.5
Wave pool	<750,000	1.5
	≥750,000	2
Activity pool	<100,000	1
	≥100,000	1.5
Multi-level play attractions	ALL	0.25

**2–36. Inlets**

*a.* Locate inlets for makeup, fresh, or treated water to produce a uniform circulation of water and to facilitate the maintenance of a uniform disinfectant residual throughout the entire pool. Place inlets and skimmers to avoid producing short-circuiting of the recirculation water.

*b.* Place wall inlets around the entire perimeter of the pool at intervals no greater than 20 feet; place one inlet within 5 feet of each corner and one inlet in each recessed step area.

*c.* Place bottom inlets around the entire perimeter of the pool at intervals no greater than 20 feet; space rows of inlets no more than 15 feet from the side walls.

*d.* Base the number of inlets on whichever of the following calculations results in the greater number of inlets—

(1) One inlet per 600 square feet.

(2) One inlet per 15,000 gallons of pool capacity.

*e.* Design or provide each inlet with an individual valve to permit adjustment of the water flow for the greatest amount of circulation.

**2–37. Outlets**

*a.* Do not connect drains to the storm sewer system. Prior to draining the pool, pool operators will notify the wastewater treatment plant (WWTP) to ensure the WWTP can

accommodate the discharge of large volumes of water. The sanitary sewer system connection may require a National Pollutant Discharge Elimination System (NPDES) permit. When draining a recreational water facility, avoid illegal discharges, and ensure full compliance with environmental regulations.

*b.* Install appropriate backflow prevention devices or air gaps to pool drains connected to a sanitary sewer system to prevent sewage contamination of the pool.

*c.* In order to maintain a swimming pool in satisfactory condition, provide some form of skimming device, such as properly designed overflow gutters or skimmers (paragraphs 2–39 and 2–40 of this bulletin). Do not permit the direct connection of skimming devices to the sewer system.

*d.* Provide bottom outlets in pools whose width is greater than 60 feet.

*e.* Provide multiple outlets at or near one end of pools with deep water, at a maximum 20-foot interval and no more than 15 feet from sidewalls. A minimum of two interconnected main drains must be provided in all newly constructed pools, spas, hot tubs, wading pools, and other recreational water facilities equipped with recirculation systems. Main drains must be spaced a minimum of 3 feet apart.

*f.* Cover outlet openings with a proper grating that is not readily removable by swimmers and meets the requirements of the VGB Pool and Spa Safety Act (see paragraph 2–38).

### **2–38. Main drains**

*a.* “Main drain” is a term that usually refers to a plumbing fitting installed on the suction side of the pump in pools and spas (that is, a suction outlet). Sometimes referred to as the drain, the main drain is normally located in the deepest area of the pool or spa. It does not literally drain the pool or spa as a sink drain would, but rather connects to the pump, allowing water to be drawn from the pool or spa for circulation and filtration.

*b.* A single main drain is a submerged suction outlet, with or without a skimmer, connected to a dedicated pool pump. A pool equipped with multiple suction outlets, each of which is connected to a dedicated pump, may have more than one single main drain. A group of connected suction outlets is considered a single main drain if the centers of the outlets are located within 3 feet of each other.

*c.* Multiple main drains consist of at least two fully submerged suction outlets per pump, with drain cover centers at least 3 feet apart. The connections between the outlets and the pump are important for proper operation and should be certified by a design professional and inspected by a licensed inspector to ensure hydraulic balance between the outlets and the main suction line to the pump.

*d.* All pools constructed after 2008 must be equipped with multiple drains, a single unblockable drain, or no main drain. Single, blockable drains are not permitted in new construction.

*e.* Drain grates must be secured in place at all times and must be observed visually on a daily basis. If the drain grate is broken or missing, the pool will be closed immediately and remain so until the grate is repaired.

*f.* In 2007, the Consumer Product Safety Commission (CPSC) established new Federal standards for swimming pool and spa safety in the VGB Act. The primary focus of the rule is to prevent injuries and deaths related to entrapment. Public pools and spas may not operate unless they comply with VGB Act requirements.

*g.* The VGB Act specifies all pools and spas must have ASME A112.19.8-compliant drain covers. Information stating that the cover or drain meets the ASME A112.19.8 standard will be embossed on the drain cover and printed in the manufacturer's specifications. Covers marked by the manufacturer with a designated life-cycle expiration date must be replaced when expired.

Covers will display—

- (1) Use (single or multiple).
- (2) Flow rate in gpm.
- (3) "Life" (number of years).
- (4) Type (wall- and/or floor-mounted).
- (5) Manufacturer's name.
- (6) Model number.

*h.* Drain cover manufacturers should provide a certification document with each drain cover stating that it complies with the requirements of the VGB Act. Such documents must be readily available and kept on file at the facility manager's office. If there is no such indication, or if the certification is in question, contact the manufacturer and ask for a copy of the certificate.

*i.* If drain covers are field-fabricated, a registered design professional or a licensed professional engineer must specify that the pre-existing grate or grates meet the ASME A112.19.8 standard.

*j.* The VGB Act also specifies that all pools and spas with a single outlet must use one of the following additional options:

- (1) Safety vacuum release system (SVRS) that complies with ASME A112.19.17 or ASTM F2387-04.
- (2) Gravity drainage system (figure 2-9).
- (3) Suction limiting vent system (figure 2-10).
- (4) Automatic pump shut-off.
- (5) Drain disablement.
- (6) Equivalent system that may be approved by the CPSC.

*k.* To ensure proper operation, all SVRS or equivalent devices must be routinely tested according to the manufacturer's recommendations.

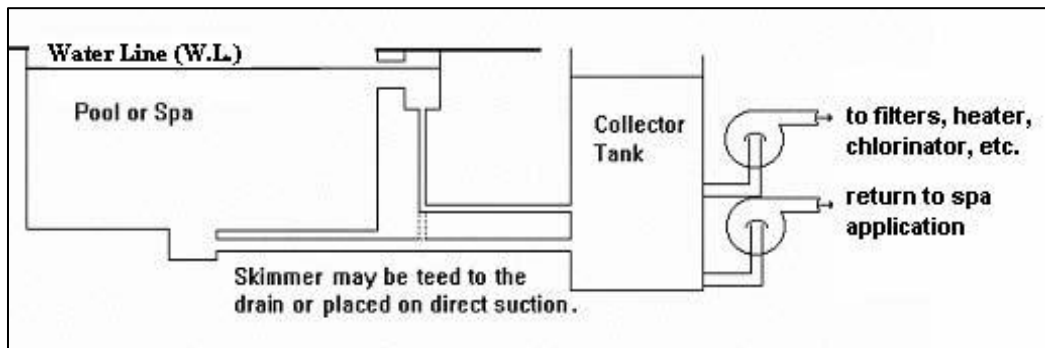

**Figure 2-9. Gravity drainage system—direct suction removed from the pool**

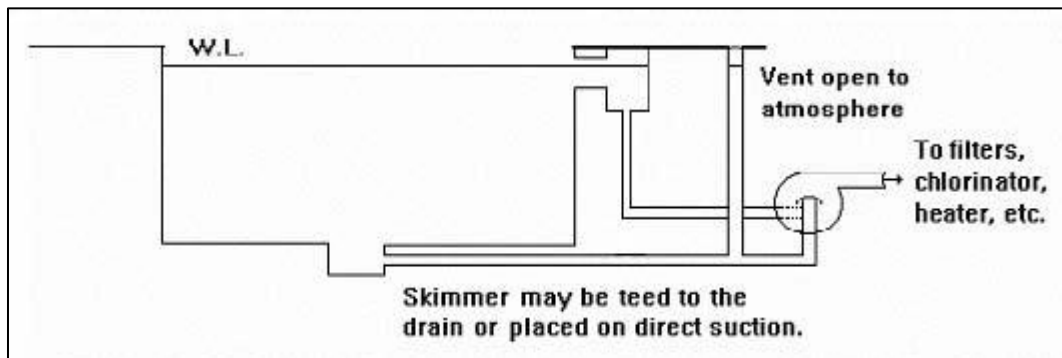

**Figure 2-10. Suction-limiting vent system to relieve main drain suction**

*l.* If the single outlet is an unblockable drain, an exception (the only exception) to paragraph 2-38j is permitted. The CPSC defines an unblockable drain as “all components, including the sump and/or body, cover/grate, and hardware such that its perforated (open) area cannot be shadowed by the area of the 18 inches x 23 inches Body Blocking Element of ANSI/ASME A112.19.8-2007 and that the rated flow through the remaining open area (beyond the shadowed portion) cannot create a suction force in excess of the removal force values in Table 1 of that Standard.”

**2-39. Overflow gutters**

- a.* When using overflow gutters instead of skimmers, install overflow gutters that—
  - (1) Extend completely around the pool, except at steps or recessed ladders in the shallow portion.
  - (2) Serve as a handhold.
  - (3) Are hydraulically capable of continuously removing at least 125 percent of the recirculating water and returning it to the filter through a surge tank located near the filter.

- (4) Are designed to prevent entrapment of the swimmers' arms or legs.
- b. Ensure the opening into the gutter beneath the coping (horizontal surface) is a minimum of 4 inches wide.
- c. Ensure the interior of the gutter is a minimum of 3 inches wide, with a depth of at least 3 inches.
- d. Provide the overflow outlets with outlet pipe at least 2 inches in diameter. The area of the grate opening must total at least 1½ times the cross-sectional area of the outlet pipe.

**2-40. Skimmers**

- a. Skimmers are limited to pools of 2,000 square feet or less, and widths less than 30 feet. When using skimmers instead of overflow gutters, install—
  - (1) A minimum of one skimming device for each 500 square feet of water surface area or fraction thereof, with a minimum of two skimmers provided.
  - (2) The skimming devices in the swimming pool water at locations that will—
    - (a) Minimize interference with each other.
    - (b) Allow proper skimming of the entire pool surface using a weir to ensure skimmer suction and performance.
    - (c) Develop sufficient velocity on the water surface to induce floating oils and wastes into the skimmer from the entire pool area, using a weir to ensure skimmer suction and performance.
- b. Ensure the skimming devices—
  - (1) Are designed to handle at least 100 percent of the required filter flow. No skimmer will have a flow-through rate of less than 30 gpm, or 3.75 gpm per lineal inch of weir (whichever is greater).
  - (2) Have an easily removable and easily cleanable screen through which all overflow water must pass to allow for removal of hair and other debris.
  - (3) Have a mechanism to prevent air locks in the suction line. Provide adequate amounts of water in a surge tank or other device to ensure proper suction.
  - (4) Are cleaned daily to prevent air locks in the suction line.
- c. When using a skimmer, equalizer piping is required.
  - (1) Size the pipe to meet the capacity requirements of the filter and pump. Never size it less than 2 inches in diameter.
  - (2) Locate the pipe no less than 1 foot below the lowest overflow level of the skimmer.
  - (3) Provide the pipe with a valve or other device that is tightly closed under normal operating conditions. The valve should automatically open when the water level drops 2 inches below the lowest weir level.
- d. Recessed automatic surface skimmers will comply in all respects with the NSF International standards for pool equipment. The NSF International Mark affixed to pool or spa equipment indicates compliance with this requirement.
- e. In the construction of new swimming pools or modification of existing pools, the prevailing summer wind direction should be considered in the placement of skimming devices.

The wind may push floating oils and wastes to an area that does not contain a skimming device, thus requiring manual cleaning.

#### **2-41. Pumps**

- a.* Pump(s) will—
  - (1) Have an adequate capacity to provide the required number of turnovers of pool water.
  - (2) When possible, be located in a position that eliminates the need for priming.
  - (3) Be capable of providing an adequate flow for the backwashing of filters.
- b.* Equip the pump suction header with a pressure gauge installed as close to the pump inlet as possible.
- c.* Ensure centrifugal pumps used for recirculation and filtration comply with NSF International standards in all respects.

#### **2-42. Piping**

- a.* Proportion and construct the piping system to permit cleaning or repair of any part of the system.
- b.* Ensure piping is nontoxic, resistant to corrosion, and capable of withstanding operating pressures.
- c.* Provide a backwash line at the lowest point of the system to permit removal of any accumulation of sediment or rust.
- d.* Provide outlets for obtaining water samples before and after treatment.

#### **2-43. Strainer baskets**

- a.* A strainer basket will be included in the recirculation system to reduce the amount of hair, lint, and other filamentous material that may reach the filters.
- b.* The strainer basket consists of a metal or fiberglass chamber containing a cylindrical strainer; the water flows from the inside to the outside of the strainer. Ensure strainers are—
  - (1) Corrosion-resistant with openings not more than one-eighth of an inch in size, providing a free-flow area at least 4 times the area of the pump suction line.
  - (2) Readily accessible for frequent cleaning.
  - (3) Equipped with a clear (see-through) top.
- c.* Ensure strainer baskets are located on the suction side of the pumps and are cleaned when necessary.

#### **2-44. Vacuum cleaners**

- a.* When fixed hose connections are used for vacuuming pools, ensure they are—
  - (1) No less than 3 inches in diameter.
  - (2) Located between 6 and 18 inches below the water surface and flush-mounted in the pool walls.
  - (3) Placed so all parts of the pool can be reached with a 50-foot hose.
  - (4) Covered when not in use.
- b.* Instead of a fixed-suction system, clean the pool with a portable suction cleaner consisting of a low capacity pump with an engine or motor mounted on a small truck/dolly for

wheeling around the pool. Do not operate this system during swimming hours; no swimmers are allowed in the pool while the vacuum is in the pool. The pump discharge may empty into the overflow gutter or deck drainage system and will not under any circumstances re-enter the pool prior to the point of filtration.

*c.* Portable electric suction cleaners will be Underwriters Laboratories (UL<sup>®</sup>)-rated and will be connected to a ground-fault circuit interrupter (GFCI)-protected electrical outlet. (UL<sup>®</sup> is a registered trademark of Underwriters Laboratories, Inc., Northbrook, Illinois.)

#### **2-45. Flow rate**

*a.* Install a meter to measure the flow rate (reading in gpm or liters per minute), preferably on the pool return line, so the rate of recirculation is indicated.

*b.* Ensure the indicator is—

- (1) Capable of measuring flows at least 1½ times the design flow rate.
- (2) Accurate within 10 percent of true flow.
- (3) Easy to read.
- (4) Installed in the center of a long run of pipe to ensure accuracy.

*c.* Pool operators will monitor the water flow rates to ensure that a constant water flow is maintained at rates according to the manufacturer's specifications and recommendations.

### **Section V: Filtration**

#### **2-46. Filtration**

Filters are a necessary part of the recirculation system that provides swimming pool water with adequate clarity. The commonly used types of filters are high-rate, rapid sand, diatomaceous earth (DE), and cartridge.

#### **2-47. Standard filter requirements**

Ensure all pressure filters—

- a.* Are capable of providing the recommended turnover.
- b.* Are designed, manufactured, and installed to provide easy accessibility for cleaning, operating, maintaining, and servicing.
- c.* Include valves and pipes to completely drain the filter. For multi-filter units, the capability to isolate, backwash, or drain an individual filter for maintenance or repair is required.
- d.* Are positioned to provide adequate circulation of air beneath and around all sides of the filter to reduce corrosion and facilitate cleaning. If filter tanks are installed in the ground (that is, buried), ensure compliance with manufacturer recommendations to protect the tanks from corrosion.
- e.* Are equipped with an approved pressure gauge(s) with appropriate capacity. Install the gauge(s) so that pressure or vacuum readings, as appropriate, may be obtained on both the influent and effluent lines of the filter(s). The difference between the gauge readings for the influent and effluent is known as the headloss of the filter.



- f. Are installed with an air-relief valve(s) located at or near the highest point of the filter(s).
- g. Are designed and constructed according to the applicable provisions of NSF/ANSI Standard 50.
- h. To discharge backwash water from these filters, it may be necessary to obtain an NPDES discharge permit from the U.S. Environmental Protection Agency (USEPA) or the state, as applicable. A more thorough discussion of filtration is presented in Unified Facilities Criteria (UFC) 3-230-02 and TM 5-662.

**2-48. Sand filters**

- a. Sand filters may be either gravity or pressure type filters, rapid-rate or high-rate.
  - (1) Filtration rates for rapid-rate sand filters shall not exceed 3 gpm per square feet of filter surface area.
  - (2) High-rate filters will be designed to operate at no more than 12 gpm per square foot.
  - (3) Use higher-rate filtration units only after such units have been successfully tested against applicable NSF standards.
- b. A sand filter intended for use in a swimming pool will be designed, constructed, and installed to filter backwash water at a rate not less than 15 gpm per square foot of filter surface area or at a rate recommended by the manufacturer. The filter backwash water shall be discharged to the sanitary sewer system. A sight glass or other means of viewing the clarity of the backwash water must be provided.
- c. Other sand filter media, such as zeolite, may be used only if the manufacturer's specifications are followed.

**2-49. Diatomaceous filters**

- a. Diatomaceous earth filters may be designed to operate either with or without continuous body feed.
  - (1) Filtration rates for DE filters that operate *with* continuous body feed shall not exceed 3 gpm per square foot of filter area.
  - (2) Filtration rates for DE filters that operate *without* continuous body feed shall not exceed 2 gpm per square foot of filter area.
- b. A DE filter intended for use in a pool will be designed, manufactured, and installed with provisions for cleaning by one or more of the following methods—
  - (1) Backwashing.
  - (2) Air pump-assisted backwashing.
  - (3) Spray wash (either mechanical or manual).
  - (4) Agitation.
- c. The water used in cleaning a DE filter shall be discharged to the sanitary sewer system or in a manner approved by the appropriate authority.

**2-50. Cartridge filters**

- a. Surface cartridge filters are designed for filtration rates not to exceed 0.30 gpm per square foot of the effective filter area.

- b. Ensure swimming pool cartridges are designed, manufactured, and installed according to the provisions and requirements for cleaning or replacement as recommended by the manufacturer.
- c. One complete spare set of cartridges shall be available at all times to facilitate cleaning.

## **Section VI: Maintenance and Water Quality**

### **2-51. Cleaning aquatic facilities**

a. To a large degree, users determine the acceptability of a facility based on the appearance of the pool or spa. Therefore, pool staff and assigned maintenance personnel should keep the facility and its area clean by—

(1) Inspecting the water daily and removing all visible foreign material. Wearing a face mask will assist in underwater visibility.

(2) Removing dirt on the bottom and any floating material at least once every 24 hours.

(3) Cleaning sidewalls daily, or as necessary, to reduce the buildup of foreign material.

b. The flushing and cleaning hose used in cleaning pool walls or walkways shall be equipped with a backflow prevention device. Swimming pool cleaning is discussed further in TM 5-662.

c. Spas must be drained and cleaned at least weekly; the dates and times of each cleaning shall be recorded.

d. Survival swimming training (drown-proofing, for example), whereby Soldiers wear utility uniforms such as the Army Combat Uniform (ACU) with boots, can have a detrimental effect on the pool.

(1) Utility uniforms and boots may be soiled, resulting in debris entering the pool. To avoid this, the units conducting such training will—

(a) Ensure that uniforms and boots are cleaned of all visible debris prior to pool entry.

(b) Provide necessary equipment (such as basins and brushes) to clean boots in the shower room prior to pool entry.

(2) The dye in new uniforms may bleed into the water. This places an excessive burden on the pool filter(s). Therefore, units performing survival swimming training should use only clean, previously washed uniforms intended for this purpose. In some cases, uniforms used for survival swimming can be maintained at the recreation facility by the unit performing the training or by the sponsoring training office.

### **2-52. Algae**

a. The growth of algae in swimming pools is promoted by—

(1) Exposure to the sun.

(2) Increased temperatures.

(3) Insufficient chlorine.

(4) Excessive amounts of ammonia and other nutrients.

*b.* The best and simplest method of algae control is to prevent the growths from forming. To effectively accomplish this, maintain at least the minimum FAC levels specified in appendix D at all times. Intermittent recirculation and chlorination are ineffective and are not allowed.

*c.* Algae development in a swimming pool can cause two types of slimy growth: free-floating or clinging. Several techniques can be used to control algae growth, once formed. These include heavy chlorination and copper sulfate treatment.

(1) Heavy chlorination, or “superchlorination,” is the preferred treatment.

(a) Increase the FAC to 5–10 mg/L for an overnight period.

(b) If higher levels are required, application of the chlorine solution by hand is an option. Hand-application of plain, unscented household liquid bleach (sodium hypochlorite 2.5–5 percent) or the clear supernatant of a 1–5 percent solution of calcium hypochlorite (well-mixed) can expedite the superchlorination buildup.

(c) Suspend swimming until the FAC is returned to the levels described in appendix D.

(2) Swimming pools that experience continuous algae difficulties due to an uncontrollable factor may require a “shock” treatment with copper sulfate. Due to its tendency, under some conditions, to form an inky precipitate that discolors swimmers’ suits and hair, seek technical advice from the manufacturer prior to using copper sulfate.

(3) As a last resort, drain the pool and scrub the bottom and sides with a 5 percent hypochlorite slurry or copper sulfate solution (non-chelated 0.2–0.3 mg/L) to remove tenacious algae growth. Personnel performing cleaning operations should wear appropriate protective clothing that limits skin exposure. Further discussion of algae control is found in TM 5–662.

**CAUTION:** Due to their toxicity, do not use mercury compounds or arsenates to remove algae growth.

### **2–53. Winterizing**

At the end of a season, outdoor pools must undergo winterization procedures to help prevent damage to the pool shell and components. The National Swimming Pool Foundation® (NSPF®) Pool & Spa Operator™ Handbook provides guidance on winterization procedures (<http://www.nspf.org/en/home.aspx>). (National Swimming Pool Foundation® and NSPF® are registered trademarks of the National Swimming Pool Foundation, Colorado Springs, Colorado; Pool & Spa Operator™ is a trademark of the National Swimming Pool Foundation, Colorado Springs, Colorado.)

## **Section VII. Bathhouse Facilities**

### **2–54. General**

All aquatic facilities, except interactive water features, must provide bathhouse facilities.

*a.* A bathhouse, located immediately adjacent to each pool, is a service facility for the activities related to a pool complex. A bathhouse provides pool patrons with dressing rooms, lockers, toilets, and a first-aid room. It may also include a snack bar and the pool's administrative facilities. In some situations, a bathhouse contains the control center, offices, staff facilities, and storage room for equipment and supplies. Often, the filter room is located in one unit of the bathhouse.

*b.* The bathhouse must be located at the shallow end of the pool and be equipped with—  
 (1) Separate facilities for males and females if both genders use the bathhouse simultaneously.

(2) Partitions consisting of tight walls or screens placed at entrances and exits to separate the area used by males from that used by females and to break the line of sight.

(3) Floors made of nonslip, impervious material with coved corners and intersections between floors and walls. Floors should not have any protrusions such as hose bibs.

*c.* In the shower, toilet, and dressing facilities, the walls, partitions, doors, lockers, and similar surfaces that require periodic cleaning shall be maintained smooth and finished so as to facilitate cleaning.

(1) Facilities shall be cleaned daily as specified in paragraph 4–1f of this bulletin to preclude the spread of infection (such as athlete's foot fungus) and the buildup of mold or mildew.

(2) Diaper-changing areas should be conveniently located near the pool so diaper-changing will be less likely to occur in the pool area.

(3) Post a sign stating patrons must shower prior to entering the pool.

## **2–55. Dressing rooms**

Dressing rooms should be equipped with the following:

*a.* Floors that slope approximately ¼ inch per foot toward the drains.

*b.* Walls and partitions of smooth, impervious materials with no open cracks or joints.

Walls and partitions made of wood or similar materials should be painted.

*c.* Partitions between dressing compartments, either raised above the floor or placed on continuous raised masonry or concrete bases.

*d.* Well-ventilated lockers, if provided, located above the floor.

*e.* Furniture that is water-resistant and easily cleaned.

*f.* A family changing room.

## **2–56. Showers**

*a.* For design or renovation purposes, provide one shower head for every 40 persons of each gender, based on the maximum facility load. Provide a minimum of two shower heads for each gender. Supply all showers with hot water, and provide adequate amounts of soap in hand-operated dispensers. Shower valves and fixtures should prevent scalding; the maximum water temperature will not exceed 110 °F.

*b.* The showers at all pools constructed after 1993 must be located such that patrons must pass through the showers en route from the bathhouse and toilets to the swimming pool.

- c. Shower floors shall be constructed of impervious nonslip material that is sloped at three-eighths of an inch per foot towards the drain.
- d. Shower curtains must be kept clean.

### **2-57. Toilet Facilities**

The total male and female toilet or urinal counts shall be according to applicable state and local codes.

### **2-58. Footbaths**

Footbaths are prohibited at Army recreational water facilities.

## **Section VIII: Utilities**

### **2-59. Heating**

a. Suggested temperatures for heated indoor pools are between 78 and 82 °F. At pools used for recreational purposes only, maintaining water temperatures above 82 °F is energy-wasteful and provides no additional comfort to the swimmer. However, different uses may require different temperatures (such as instruction versus lap swimming).

b. Blowing steam directly into the pool or placing heating coils in the pool is prohibited.

c. Use a thermostatically-controlled heater designed to warm all or part of the recirculating water. Place one fixed thermometer in the recirculation line at the heater outlet and another near the pool outlet.

d. In pools designated for physical therapy use only, the water temperature may be maintained between 90 and 96 °F for patient comfort.

e. The potential for hypothermia increases as the temperature decreases. In pools without a means of temperature regulation (that is, outdoor pools), limit recreational swimming to a maximum of 25 minutes per hour when water is less than or equal to 70 °F (21 °C). Discretion is left to pool operators in consultation with the medical authority regarding closure of pool facilities when concerns regarding hypothermia arise. Pool operators should consider wind chill and any other pertinent factors in addition to the ambient air temperature when considering hypothermia concerns.

f. Water temperatures in spas shall not exceed 104 °F. Temperature controls for hot water facilities must be locked or otherwise made inaccessible to users.

(1) Limit patrons to 15-minute exposures at 104 °F.

(2) A directly accessible timer switch that automatically shuts off the hydrotherapy jets and air blowers must be located adjacent to the spa. The maximum amount of time allotted on the timer shall not exceed 15 minutes, and the timer switch shall not be accessible from within the spa.

(3) There is evidence that exposure to elevated temperatures of a spa or hot tub can have a damaging effect on the developing fetus. Pregnant women should not use spas or hot tubs; a sign must be posted at the spa/hot tub to warn pregnant women of this potential hazard.

*g.* Alcoholic beverages are not allowed to be consumed before or during spa use. Appendix C contains additional rules for spa use.

## **2-60. Ventilation**

*a.* Aquatic facility building ventilation systems must be designed, constructed, and installed to protect the health of the building's occupants. The ventilation systems shall be maintained and operated in compliance with all requirements of the original system design, construction, and installation.

*b.* Indoor aquatic facility operators must develop and implement a ventilation system program of standing operating, maintenance, testing, and inspection procedures which provide detailed instructions, identify necessary equipment and supplies, and establish oversight for those performing these duties, according to the aquatic facility ventilation system design engineers' and/or ventilation system manufacturer's recommendations.

*c.* Indoor aquatic facility operators shall monitor, log, and maintain ventilation system set-points and other operational parameters as specified by the aquatic facility ventilation system design engineer and/or the ventilation system manufacturer.

*d.* Indoor aquatic facility operators shall implement a ventilation system cleaning program to remove contaminants within the equipment according to the aquatic facility ventilation system design engineers' and/or the ventilation system manufacturer's recommendations.

*e.* Indoor aquatic facility operators shall retain the ventilation system design engineer's original operating manuals and commissioning reports, any updates and/or modification specifications.

*f.* Ventilation rates at all indoor aquatic facilities shall be according to American Society of Heating, Refrigerating, and Air-Conditioning Engineers (ASHRAE, Inc.) Standard 62.1 (ANSI/ASHRAE Standard 62.1).

*g.* Dressing rooms, toilet rooms, and shower rooms shall be ventilated by natural or artificial means to prevent odors and to dry floors, walkways, benches, and other areas that become wet. A minimum ventilation rate of 0.5 cubic feet per minute per square foot (cfm/sq ft) is suggested to achieve proper ventilation.

*h.* Indoor pools shall be ventilated to prevent the accumulation of moisture and condensation on cold surfaces. Sufficient ventilation will be provided to dry floors, decks, and other surfaces in less than 90 minutes.

*i.* The ventilation system design for chemical storage rooms shall conform to the International Mechanical Code<sup>®</sup>, International Fire Code<sup>®</sup> and any applicable local codes. (International Mechanical Code<sup>®</sup> and International Fire Code<sup>®</sup> are registered trademarks of the International Code Council<sup>®</sup>, Washington, D.C.)

*j.* Indoor water park facilities with features that create water aerosols may require additional ventilation.

## **2-61. Lighting**

*a.* Illumination standards for bathhouses and other interior pool facilities are provided in UFC 3-530-1. Illumination for exterior swimming pool facilities shall be provided based on

standards of the Illuminating Engineering Society's current recommended practice for sports lighting.

*b.* Outdoor pool area floodlights shall be located outside the deck of the pool to prevent light-attracted insects from dropping into the pool.

*c.* Underwater lights must allow an observer on the pool deck to clearly see all portions of the pool, including the bottom.

*d.* Adequate emergency lighting shall be provided at pools where night swimming is allowed and at indoor pools where no natural light is present or where natural, daytime illumination is inadequate or presents a safety hazard.

*e.* Windows and lighting equipment must be adjusted to prevent glare and excessive reflection on the pool surface.

## **2-62. Electrical**

*a.* Construct and install all electrical wiring and equipment to meet or exceed the most current requirements of the National Fire Protection Association (NFPA<sup>®</sup>) NFPA 70<sup>®</sup> standard (the National Electrical Code<sup>®</sup> (NEC<sup>®</sup>)), Article 680; NFPA 70E<sup>®</sup>, Standard for Electrical Safety in the Workplace; AR 385-10, Army Safety Program, chapter 25; and DA PAM 385-26, Army Electrical Safety Program. (NFPA<sup>®</sup>, NFPA 70<sup>®</sup>, and NEC<sup>®</sup> are registered trademarks of the National Fire Protection Association, Quincy, Massachusetts.)

*b.* The installation of ground-fault circuit interrupters (GFCIs), where required, is critical to the safety of personnel at all pool facilities.

(1) Equip all electrical circuits located within 6 feet of a pool, wading pool, spray pool, or spa with GFCIs that conform to DA PAM 385-26 and NFPA 70, Article 680.

(2) Equip bathhouses with GFCIs.

*c.* Overhead electrical wiring may not pass horizontally within 20 feet of the pool.

*d.* Portable electrical devices (such as announcing systems and radios) are prohibited within the reach of bathers.

*e.* All pumps, filters, and other mechanical and electrical equipment shall be enclosed in such a manner as to be accessible to authorized persons only.

## **Section IX. Spectator and Concession Areas**

### **2-63. Spectator areas**

Install a separate entrance for the spectator area, if such an area is provided. Ensure the spectator area does not overhang and is not located closer than 10 feet from the edge of the pool. This distance minimizes the possibility of spectators dropping food or other items into the pool.

### **2-64. Concession areas**

*a.* Concession areas may be designated at both swimming pools and natural bathing areas. It is important to recognize that concession areas may present a problem in terms of sanitary control.

- (1) At pools, separate the concession area from decks and pool walkways.
- (2) Maintain concession areas in a sanitary manner by—
  - (a) Prohibiting glass in the area.
  - (b) Requiring patrons to dispose of refuse (such as cans or wrappers) in the concession area prior to returning to the deck or pool area.
  - (c) Providing covered trash receptacles and ensuring they are emptied frequently.
- b. All food service sanitary requirements pertaining to these facilities will apply (AR 40–5 and TB MED 530).

## **Section X. Landscaping, Fencing and Enclosures**

### **2–65. Landscaping**

- a. Design the area around outdoor recreational water facilities to prevent surface drainage from entering the facility.
- b. Minimize the amount of dirt, dust, and debris carried/blown into the facility by ensuring the top of the facility is placed well above the surrounding ground level.
- c. Do not plant trees and shrubbery in locations where leaves and blossoms can fall into the facility.

### **2–66. Fencing and enclosures**

- a. Provide barriers to prevent drowning, near-drowning injuries, and the unauthorized use of aquatic venues. Fences and similar enclosures are effective in preventing these deaths and injuries, particularly among children.
- b. Barriers shall be constructed according to the state or local building code.
- c. Enclosures shall be constructed in such a manner as to discourage climbing. Horizontal mid-rails are not permissible. Where a chain-link fence is provided, ensure the openings between links do not exceed 1 inch, or provide slats on the fence so the openings do not exceed 1 inch.
- d. Design or construct access gates to be—
  - (1) Equal in height, at top and bottom, to the barrier of which they are a component.
  - (2) Self-closing and self-latching from any open position.
  - (3) Installed to open outward, that is, away from the pool or spa.
  - (4) Equipped to accommodate a lock.
- e. When the pool is not supervised, the gate or door shall be locked, and access to the pool shall be prevented.
- f. Propping open gates or doors is prohibited.
- g. Construct all barriers around pools or spas so there are no footholds or other physical characteristics that would enable a child to climb over the barrier. Masonry and stone barriers may not contain indentions or protrusions except for normal construction tolerances.
- h. When a wading pool is located adjacent to a pool—
  - (1) Provide a toddler-proof barrier, such as a fence with a gate, to separate the two pools.



(2) Design the wading pool fence to conform to the same fence requirements as those stated in the paragraphs above.

(3) Equip fence gates or doors with self-closing and positive self-latching closure mechanisms and permanent locking devices.

## CHAPTER 3

### NATURAL BATHING AREA DESIGN

---

#### 3–1. General

One of the primary requirements of natural bathing areas is the protection of the health and safety of the users of these facilities, considering—

- a. Physical characteristics.
- b. Support facilities.
- c. Water quality (chapter 4).
- d. Lifesaving and safety equipment (chapter 4).

#### 3–2. Natural bathing area design

a. Site selection for a natural bathing area is critical to maintaining good sanitary quality. In evaluating beaches for recreational use or training, select only those areas that are remote from sources of pollution (such as wastewater discharge). Adequate water circulation is required to minimize the high bacterial counts that may occur when a large number of swimmers are in the water. Good water circulation will generally remove surface debris such as weeds or other floating objects.

b. Avoid areas with native populations of waterfowl (see figure 3–1). Prohibit the feeding of animals or migratory waterfowl, as feeding them may encourage them to remain in the area. The presence of birds increases the chances of contaminating the beach with pathogenic bacteria such as salmonella. Except as stated in subparagraph 4–1e(1), pets and other domestic animals are not permitted in the water, on the property, or in the buildings.



**Figure 3–1. Waterfowl contamination concern**

*c.* The ideal beach is one that provides the swimmer with protection not only from sources of pollution but also from boats, boat wakes, fuel spillage, and other hazards.

(1) Situate the beach to ensure maximum solar exposure; however, avoid western exposure to reduce afternoon glare to lifeguards.

(2) Consider prevailing winds to reduce debris accumulation on the beach.

*d.* The slope of the land, both above and below the water line, is important. Ensure slopes in the underwater portion of the beach are gradual, uniform, and have ratios preferably no greater than 1 in 15 (1:15) in the non-swimming areas or 1 in 10 (1:10) in the swimming areas. Ensure there are no submerged rocks, sudden drop-offs, or other underwater hazards.

*e.* To determine beach capacity, allow 50 square feet of swimming area and 50 square feet of beach area per person. At any one time, expect 60 percent of the swimmers to be on the beach, 30 percent in the water, and 10 percent elsewhere.

### **3–3. Depth and type of sand**

*a.* The minimum depth of sand on the beach area and within the non-swimming area is 20 to 24 inches. If the sand layer is less than 20 inches, it may easily erode from wave action.

*b.* It may be necessary to import sand to create desirable beach conditions. Coarse-grain sand is the most practical for resisting wave action. Fine-grain sand is easily eroded and may cause some turbidity of the water when agitated. White sand tends to be more aesthetically pleasing than brown sand but creates more glare. When an option is possible, coarse, natural brown sand is recommended.

### **3–4. Diving areas**

Designated diving areas tend to enhance the use of natural bathing facilities. However, exercise care to prevent the creation of safety hazards.

*a.* Locate diving rafts or floats where the minimum depth of the water is 9 feet, extending a distance of at least 10 feet forward of the diving direction. The maximum allowable water depth of diving areas in natural bathing facilities is 17 feet.

*b.* If diving boards or platforms are installed 3 feet or less above the water, the minimum water depth is 10 feet, extending at least 12 feet beyond the diving surface.

*c.* If diving boards or platforms are installed at heights greater than 3 feet above the water, the minimum water depth at those locations shall be 12 feet, extending a distance of 20 feet beyond the diving surface. Diving devices placed more than 10 feet above the water are not allowed.

*d.* If a raft or float is located where the water depth is less than 9 feet, post conspicuous and easy-to-read signs that prohibit diving (see figure 2–2).

### **3–5. Support facilities**

*a.* Provide at least one bath change shelter for each natural bathing area. Whenever possible, combine dressing rooms with toilet facilities and showers.

(1) Locate the facility approximately 200 feet from the water's edge.

(2) Design the floors of the bathhouse with an easy-to-clean material with a nonslip surface that is impervious to moisture and sloped to allow drainage of water.

(3) To determine the number of required toilet fixtures, see paragraph 2–57 of this bulletin.

*b.* Refreshment stands provided at natural bathing areas may range from a small vending machine to large snack bars. Sanitary control of food establishments and operations shall be according to TB MED 530.

*c.* Provide properly covered, leak-proof trash receptacles in the vicinity of the refreshment stands and on the beach.

### **3–6. Beach operations**

*a.* At year-round natural bathing areas, the maintenance program includes—

(1) The beach area.

(2) Support facilities, including stands with equipment.

(3) Concession buildings.

(4) Parking areas.

(5) Walkways.

(6) Access roads.

*b.* Competent beach management personnel are essential to proper beach operation, which is necessary for health and safety reasons.

*c.* Enact and enforce regulations pertaining to the safe and healthful use of natural bathing areas. Make these regulations available to all who use the facility. Suggested guidelines for enacting and enforcing regulations at natural bathing areas are provided in chapter 4, section IV.

## CHAPTER 4

HEALTH AND SAFETY CONSIDERATIONS

---

## Section I. Health Considerations in Aquatic Venues

**4-1. Sanitation and disease transmission**

*a.* Recreational swimming provides leisure, physical therapy, and training opportunities for Soldiers and their families. Proper operation and maintenance of these facilities in accordance with the requirements of this bulletin, TM 5-662, and manufacturer specifications is necessary to protect the public from diseases associated with recreational waters and supporting facilities.

*b.* Individuals using these facilities must be protected from the transmission of disease.

(1) Current epidemiological evidence indicates that well-constructed, -operated, and -maintained swimming and bathing facilities do not present major public health concerns. However, operating a facility without adequate regard for proper sanitary control and safety can and has resulted in injury, death, and the spread of disease.

(2) Vigilance by all personnel involved in the operation, maintenance, and sanitary control of swimming and bathing facilities is critical to preventing disease outbreaks and injuries and maintaining the facilities for their intended purpose.

(3) Employees and users (patrons) must be free of infectious and communicable diseases.

*c.* Diseases and illnesses associated with swimming and bathing facilities are classified into the following broad categories:

- (1) Gastrointestinal diseases.
- (2) Respiratory diseases.
- (3) Diseases of the eye, ear, nose, and throat.
- (4) Infections of the skin.
- (5) Chemical toxicity.

*d.* Disease transmission hazards are the greatest among swimmers in swimming pools because these swimmers tend to ingest more water than swimmers in the brackish estuarine water and saline water of the open seas. In addition, children generally ingest more water than adults.

*e.* Efforts shall be made to prevent unsanitary conditions that could lead to the spread of disease at recreational water facilities. For example—

(1) Pets and other domestic animals are not permitted in the water, on the property, or in the buildings serving recreational water facilities. To prevent unsanitary conditions, discourage the presence of wildlife, to include the feeding of animals. An exception is provided for service animals that are controlled by the disabled person. According to the 2010 revised ADA requirements, when the particular service provided by such an animal is not obvious, only limited inquiries are allowed. Recreational water facility staff may ask two questions: (1) Is the

service animal required because of a disability, and (2) What work or task has the service animal been trained to perform? Staff may not inquire as to the person's disability and may not request medical documentation, a special identification card or training documentation for the animal, or that the animal demonstrate its ability to perform its assigned work or task. The service animal must be allowed to accompany the disabled individual to all areas of the facility where customers are permitted, except into the pool or spa water (where animals may present sanitary concerns).

(2) Water in the pool and residual or standing water on pool covers, pool equipment, and other surfaces shall be treated in such a manner as to prevent algae growth and mosquito breeding.

(3) If there is a suspicion that individuals may have contracted an illness as a result of exposure to a recreational water facility, the medical commander shall investigate immediately and implement remedial measures as appropriate (see paragraph 4–7). Such measures may include chemical and bacterial water sampling, adjustment of water quality parameters, disinfection of facilities, and/or temporary closure of the facility.

(4) The following illnesses, in particular, warrant immediate action if it appears a swimmer may have been sickened from recreational water facility use:

- (a) Giardiasis.
- (b) Cryptosporidiosis (figure 4–1).
- (c) *Pseudomonas aeruginosa* dermatitis or folliculitis.
- (d) *Staphylococcus aureus* infection.
- (e) *Legionella pneumophila* infection.
- (f) *Mycobacterium* spp. infection.
- (g) *Acanthamoeba keratitis*.

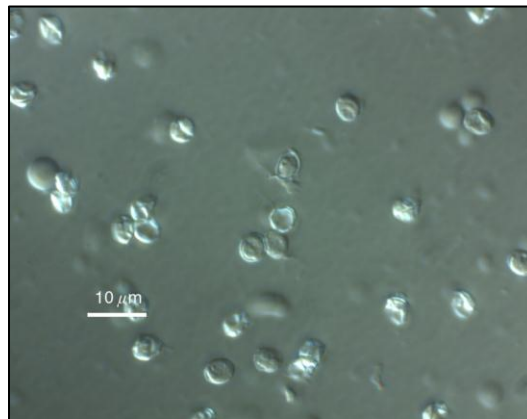

**Figure 4–1.** *Cryptosporidium parvum* oocysts

f. Facility operators must maintain sanitary control over the supporting components and services associated with the recreational water facility.

(1) After each use by a single patron, issued towels shall be laundered. Labeled containers shall be provided for storing soiled items. Clean items shall be protected from becoming soiled during storage.

(2) After each use by a single patron, issued shower shoes designed for multiple use shall be cleaned and disinfected with a minimum concentration of 500 mg/L bleach solution or other EPA-approved disinfecting product. (Refer to the glossary for additional guidance regarding “EPA-registered” and foreign brand disinfection products.) Disinfection products shall be effective against the greatest spectrum of fungi, viruses, and bacteria, to include methicillin-resistant *Staphylococcus aureus* (MRSA).

(3) Showers, toilet facilities, locker room floors and benches, and diapering areas shall be cleaned and disinfected at least daily. Showers shall be free from soap scum, mineral buildup, and mildew/mold. Disinfect cleaned surfaces using EPA-registered products or approved equivalents according to the manufacturer’s label. Chlorine bleach solutions prepared on site shall be prepared fresh daily and applied using the appropriate concentration for the treated surface and minimum wet contact time as specified in table 4–2.

(4) Soap supplied for showers shall be single-use bar soap or soap in bulk liquid or powder form supplied from a mounted dispenser.

(5) Whirlpool baths, steam cabinets, and other therapy-type equipment shall be cleaned and disinfected between users. Either a chlorine disinfectant solution containing a minimum of 50 parts per million (ppm) FAC or an iodine disinfectant providing the equivalent of 25 ppm free available iodine may be used. The minimum wet contact time to achieve adequate disinfection at these concentrations is one minute. Equipment must be rinsed with potable water after disinfection.

#### **4–2. Diseases**

*a.* Since 1978, waterborne disease outbreaks (WBDOs) associated with recreational water in the U.S. have been tracked via the Waterborne Disease Outbreak Surveillance System. Every two years, the CDC publishes summary reports of the data it has collected. The predominant illnesses reported include acute gastrointestinal illness (AGI), acute respiratory illness (ARI), and skin disease, with the largest occurrence consisting of AGI. Table 4–1 summarizes the disease agents commonly associated with outbreaks resulting from exposure to treated recreational waters.

**Table 4–1. Etiologic agents in recreational water-associated outbreaks (pools and spas), 2005–2010**

DISEASES	OUTBREAK OCCURRENCE		
	2005-2006	2007-2008	2009-2010
	n=53 (4086 cases)	n=99 (12,636 cases)	n=47 (1030 cases)
<i>Cryptosporidium</i> spp.	54.7%	58.6%	51.1%
Norovirus	1.9%	2.0%	--
<i>Shigella</i> spp.	1.9%	2.0%	2.1%
<i>E. coli</i>	--	2.0%	2.1%
<i>Giardia</i>	1.9%	3.0%	2.1%
<i>Campylobacter</i>	1.9%	--	--
<i>Pseudomonas aeruginosa</i>	7.5%	4.0%	8.5%
<i>Legionella</i> spp.	15.1%	10.1%	8.5%
Multiple (includes <i>Plesiomonas</i> , <i>Yersinia enterocolitica</i> or other mixed agents)	1.9%	1.0%	--
Unidentified (includes suspected agents)	13.2%	17.2%	25.5%

b. If a recreational water facility is inadequately disinfected, all of the common waterborne diseases spread by ingestion, in addition to various other diseases, may be transmitted. The importance of recreational water quality cannot be overemphasized.

c. Spas, in particular, require attentive operation. Warm water temperatures, low water volume, potential water chemistry and filtration problems, and excessive bathing load can all contribute to the spread of illness if not controlled appropriately.

#### 4–3. Monitoring devices

a. Proper balance of water at aquatic venues is vital to ensuring the safety of swimmers. Frequent monitoring of water quality parameters, inspections, and proper cleaning of the facilities will help prevent disease transmission and provide a safe environment for facility patrons. Appendix D lists the water quality standards that aquatic venues must meet to maintain proper water balance.

b. The pool operator responsible for maintaining proper pool balance must have the following on hand in order to comply with the monitoring requirements as described in 4–13 and 4–16:

(1) Colorimetric test kits or test strips for the determination of disinfecting agent (FAC or total bromine) residual, as appropriate; the pH of the pool water; total alkalinity; and calcium hardness. A supply of appropriate reagents for performing each type of test shall be provided. Electronic residual and pH monitoring devices may be used in addition to the test kit.

(2) A Diethyl-P-Phenylene Diamine (or DPD) test kit for measuring chlorine residual. This required test kit must be scaled, at a minimum, with the following increments: 0.2, 0.4, 0.6,



0.8, 1.0, 1.5, 2.0, and 3.0. Pool operators must also have the means by which to verify higher than normal residuals, such as when superchlorinating the water or during a contamination response.

(3) A pH test kit with a range from 6.8 to 8.2, accurate to the nearest 0.2 pH unit.

(4) A cyanuric acid concentration test kit with a range of 0–100 mg/L and accurate within 5 mg/L. This test kit shall be provided at each swimming pool that uses cyanuric acid or chlorinated cyanurates.

c. Chemical testing reagents must be checked for expiration at every use.

d. Test kits for disinfecting agent residual determination and pH, meeting the applicable requirements of 4–3b(1)–(3), must be maintained at the pool to comply with daily monitoring requirements. These kits shall be stored according to the manufacturer’s specifications.

e. An unbreakable thermometer or temperature measuring device that is easily viewed by patrons shall be placed in the spa. The temperature of each heated spa must be monitored every 2 hours and posted on the spa caution sign or monitored continuously by automated equipment that displays the temperature within sight of the spa.

#### 4–4. Bacteriological water quality

a. The basic purpose of a bacterial quality indicator of water in a swimming pool or spa is to confirm the accuracy of the disinfectant and pH tests. If the FAC and pH values are greater than the minimum values stated in appendix D, then the pool or spa water should be of acceptable bacterial quality. However, problems such as those with the distribution system may result in invalid tests.

b. Use the heterotrophic plate count (HPC) as the bacteriological quality indicator of the water in swimming pools, spas, and APFs. The HPC testing remains the simplest and most efficient method of determining the bacterial quality of water in a swimming pool or spa; it is a measure of the effectiveness of disinfection. Most organisms responsible for skin, eye, ear, nose, and throat infections and those causing gastroenteritis grow rapidly on HPC agar. As an absolute minimum, test HPC levels weekly as an indicator of water quality. Monitoring for other indicators (such as coliforms, *Escherichia coli* (*E. coli*), and staphylococci) may augment HPC testing as necessary.

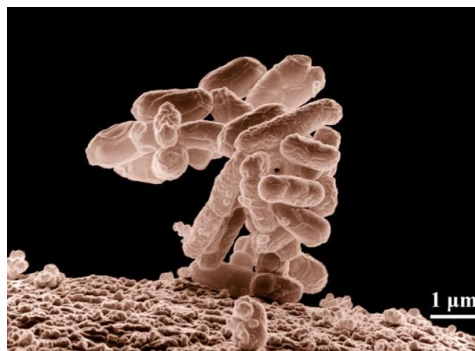

Figure 4–2. *Escherichia coli* bacteria

c. Conduct all tests for bacteriological indicator organisms according to the current edition of the American Public Health Association (APHA)/AWWA/Water Environment Federation (WEF) Standard Methods for the Examination of Water and Wastewater, using methods approved by the USEPA for use in drinking water.

#### 4-5. Bacteriological laboratory analyses

a. Preventive medicine/public health shall maintain the capability to perform HPC analyses. More specific bacterial identification may require outside laboratory assistance.

(1) A laboratory performing HPC testing may use any USEPA-approved method, including pour plate, spread plate, membrane filtration (MF) techniques, or pre-packaged, commercially available products. A current list of USEPA-approved methods is presented in Title 40, Code of Federal Regulations (40 CFR), Section 141.74.

(2) Record the medium used and the incubation temperature and duration. (Use the appropriate formulation of agar based on the HPC testing technique chosen from the APHA/AWWA/WEF Standard Methods for the Examination of Water and Wastewater.)

(3) Bacterial colony count on HPC agar is attained after a 48-hour incubation period at  $35\pm 0.5$  degrees Celsius ( $^{\circ}\text{C}$ ). Satisfactory water quality for aquatic venues is indicated when HPC results yield less than or equal to 200 colony forming units (CFU) per 1 mL.

(4) If the HPC exceeds 200 CFU/mL of sample, collect and analyze additional samples immediately. Review the facility's operating records for any irregularities in the operation, and evaluate the operator's procedures when testing the water for pH, residual disinfectant, and other water quality parameters.

b. *Other bacterial indicators.*

(1) The total coliform test may provide additional useful information about the sanitary quality of indoor pool water. Use either the defined substrate technology (for example, Colilert<sup>®</sup>), MF, or the multiple tube fermentation (MTF) method to perform this test. (Colilert<sup>®</sup> is a registered trademark of IDEXX Laboratories, Inc., Westbrook, Maine.)

(a) The defined substrate technology is based on the premise that only the specific species of bacteria that are able to metabolize the nutrients in the medium will grow and produce a positive test.

(b) The minimal medium ortho-nitrophenyl- $\beta$ -D-galactopyranoside (ONPG) and 4-methylumbelliferyl- $\beta$ -D-glucuronide (MUG) (MMO-MUG) is a test that indicates both the presence of total coliforms and *E. coli* in the same test vessel after a 24-hour incubation.

(c) If using the defined substrate technology without equipment to quantify total coliforms, the analysis must show no positives.

(2) When using the MF procedure, the total coliform level may not exceed 2 CFU/100 mL of sample. Analysis using the five-tube MTF technique must yield no positives. Use the fecal coliform test to provide supplementary information for disinfected outdoor pools.

(a) The MTF method, which produces a most probable number (MPN) value, is a statistical number and technically may not be used to obtain a mean value from a series of samples. It is acknowledged that some agencies average the MPN values.

(b) If the MTF method is used to determine the density of indicator organisms, and if a central value is desired, use the median of the values instead of an arithmetic or geometric mean.

(3) If the water in a swimming pool or spa is suspected in the transmission of disease, tests may be warranted for other bacterial agents such as staphylococci and *Pseudomonas* (*P.*) *aeruginosa*. *P. aeruginosa* is associated with spa waters in particular. Methods for the enumeration of these species are in the current edition of the APHA/AWWA/WEF Standard Methods for the Examination of Water and Wastewater. The level of staphylococci should not exceed 50 CFU/100 mL of sample. No maximum acceptable value has been established for *P. aeruginosa*. Until a maximum value is established, use a guideline value of less than 1 CFU/100 mL of sample.

#### 4-6. Collection of samples for laboratory analysis

a. At a minimum of once a week, preventive medicine/public health personnel shall collect samples for bacteriological examinations and concurrent pH and chlorine residual measurements of swimming and bathing facilities.

(1) Collect swimming pool samples from both the deep and shallow ends during the period of heaviest swimming loads.

(2) Collect spa water from any point within the tub.

b. When collecting samples for laboratory examinations, use only clean, wide-mouth, sterilized bottles made of borosilicate (or equivalent) glass or polypropylene (autoclavable) plastic with suitable caps/stoppers. Commercially packaged sterile sample bags containing sodium thiosulfate are also acceptable. If testing chlorinated water, add sodium thiosulfate to the bottle before sterilization to retard the action of the chlorine prior to the bacteriological examination. Add sodium thiosulfate in the form of—

(1) Crystals (0.02–0.05 gram (g) dry weight).

(2) A sterile solution (approximately 0.1 mL of a 10-percent solution) for a 120-mL sample.

(a) Ensure the sodium thiosulfate solution is clear, free of microorganisms, and stored in the dark.

(b) Prepare fresh solutions at least quarterly but more frequently if microbiological quality is not adequately maintained.

c. Perform the sampling procedure as follows:

(1) Carefully remove the cap or stopper from the bottle without touching either the inner surfaces of the stopper or the top of the bottle.

(2) Hold the sterile bottle near its base and at a 45-degree angle.

(3) Fill the bottle in one slow sweep by plunging it, mouth end down, at a depth of 12–18 inches in the water with the mouth of the bottle always ahead of the hand.

(4) Avoid contamination of the sample by floating debris.

(5) Replace the stopper or cap.

- d.* Do not rinse the bottle in the pool because the sodium thiosulfate will be removed. Exercise care not to lose the sodium thiosulfate (if used) when plunging the bottle to collect the samples. For stream samples, move the bottle against the current.
- e.* At the time of collection, identify samples with date, time, location, and sampler's name (initials). Transport samples to the laboratory in a clean ice chest, protecting them from exposure to high temperatures and outside contamination.
- f.* Examine the samples as soon as possible after their collection.
- (1) Examine unrefrigerated samples within 1 hour.
  - (2) Examine refrigerated samples, maintained at approximately 40 °F (4 °C), within 6 hours but in no instance more than 30 hours after collection. If a delay in laboratory analysis is unavoidable, special techniques for filtering the sample onsite, followed by delayed incubation in a laboratory, are necessary. (See the current edition of the APHA/AWWA/WEF Standard Methods for the Examination of Water and Wastewater for detailed guidance.)

#### **4-7. Bacteriological sample exceedance**

- a.* Should bacteriological standards be exceeded, take the following actions:
- (1) Collect repeat samples promptly at the points of the previous collection.
  - (2) Expedite the shipment of samples so the laboratory report can be obtained promptly.
  - (3) Investigate immediately to determine whether any unusual conditions such as repairs to facilities, storms (if an outdoor facility), drown-proofing at the facility, or other activities may have caused a problem. Also, determine if the filtration and disinfection systems have been operating properly.
  - (4) Ensure that pH and chlorine residuals are within acceptable ranges (appendix D).
  - (5) Attempt to identify the specific organisms causing excessive bacterial counts. Seek the advice of the U.S. Army Medical Department Activity/U.S. Army Medical Center (MEDDAC/MEDCEN) laboratory serving the installation for organism identification.
- b.* If the results of the resample again exceed standards, close the facility until the cause of the problem is determined. Superchlorination of the pool may be required (paragraph 2-26g) to reduce the bacterial presence to acceptable levels.

#### **4-8. Fecal contamination**

- a.* Fecal contamination of pools can be a common occurrence, creating aggravation for both pool operators and patrons. Fecal matter from "accidents" can contain pathogens which are then released into the pool water. This occurrence poses a higher risk of illness to the swimmers, who may inadvertently ingest the contaminated water.
- b.* To avoid the spread of disease through fecal contamination, aquatic venues must be operated and maintained at optimal levels. Institute the protective measures in figure 4-3.

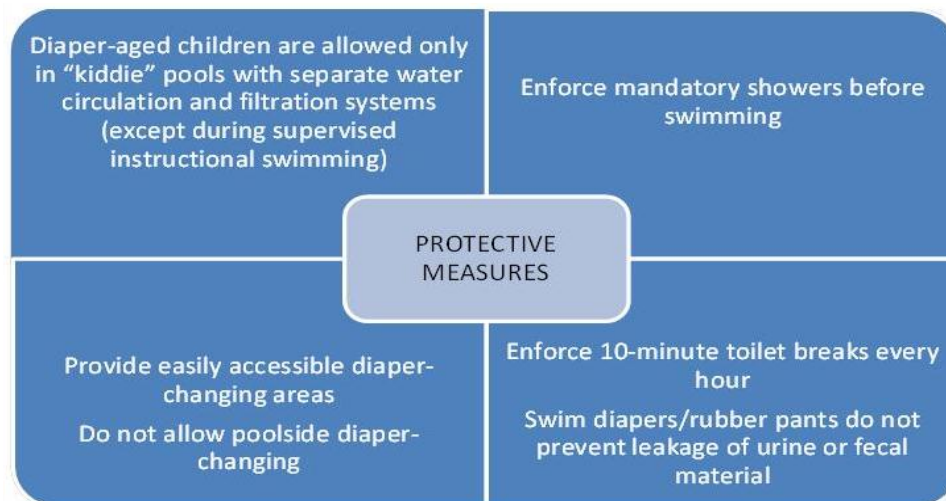

**Figure 4–3. Measures for protection against fecal contamination**

c. Post a sign with the following language in a conspicuous location before pool entry:

- Do not use the pool if you or your child has had diarrhea in the previous 2 weeks.
- Wash your child thoroughly (especially on the rear end) with soap and water before swimming.
- Do not change your child's diaper at poolside.
- Do not rinse diaper-aged children in the pool before, during, or after diaper changes.
- Assist young children in making frequent visits to the bathroom to minimize accidents.
- Do not rinse hands in the pool following a trip to the bathroom or after changing a child's diaper. Wash hands thoroughly with soap and water prior to entering the pool area.
- Do not swallow pool water.
- Do not breastfeed your child in the pool.
- Notify pool management if you or a family member develops a gastrointestinal illness that you think may have been related to a visit to the swimming pool.

#### **4–9. Contamination response plan**

a. All swimming pool facilities shall have a contamination response plan for responding to formed-stool contamination, diarrheal-stool contamination, vomit contamination, and contamination involving blood. The contamination response plan should include guidance for incidents involving dead animals and avian fecal contamination. Guidance for these types of incidents is available from the CDC at

<http://www.cdc.gov/healthywater/swimming/pools/animals/>.

*b.* The contamination response plan must include procedures for response and cleanup, provisions for training the staff in these procedures, and a list of equipment and supplies for clean-up.

*c.* Recreational water facility managers shall review the response plan at least annually and update its procedures, as necessary, according to current CDC recommendations. Preventive medicine/public health shall be included in the review process.

*d.* All recreational water facility operators, maintenance staff, and lifeguard staff shall be—

(1) Trained in the procedures for responding to formed-stool contamination, diarrheal contamination, vomit contamination, and blood contamination.

(2) Trained in universal precautions, personal protective equipment, and other measures to minimize the exposures to bodily fluids that employees in an aquatic environment may encounter.

*e.* A “Water Contamination Response Log” shall be maintained for pool staff to document each occurrence of contamination in the water or areas immediately adjacent to the water by formed or diarrheal fecal material, whole stomach discharge of vomit, and blood. Refer to appendix F for an example log.

#### **4–10. Water contamination response**

*a.* In the event of a fecal or vomit contamination in a disinfected water venue, the operator shall immediately close the pool to swimmers until remediation procedures are completed. This closing includes the affected water feature and other features that share the same recirculation system.

*b.* Contaminating material shall be removed (by using a net, scoop, or bucket, for example) and disposed of in a sanitary manner.

(1) Equipment (such as a net or bucket) used to remove contaminants shall be cleaned with a detergent solution and then disinfected as specified in table 4–1. Cleaned equipment may also be disinfected by immersing it in the pool during the disinfection procedure prescribed for formed-stool, diarrheal-stool, or vomit contamination (see paragraph 4–11).

(2) Aquatic vacuum cleaners may not be used for removal of contamination from the water or adjacent surfaces unless vacuum waste is discharged to a sanitary sewer and the vacuum equipment can be adequately disinfected.

*c.* Pool water that has been contaminated by feces, vomit, or blood shall be treated as follows:

(1) Check to ensure the water pH is 7.5 or lower; adjust as needed.

(2) Verify and maintain the water temperature at 77 °F (25 °C) or higher.

(3) Operate the filtration/recirculation system while the pool reaches and maintains the proper free chlorine concentration during the remediation process.

(4) Test the chlorine residual at multiple sampling points to ensure the proper free chlorine concentration is achieved throughout the pool for the entire disinfection time.

**4–11. Pool water contamination disinfection**

Proper water contamination response procedures must be implemented immediately following a contamination event. The CDC MAHC, section 6.5.3., provides the following guidance and alternative parameters for achieving disinfection:

*a. Formed-stool contamination.* Raise the FAC to 2 mg/L and maintain this level for at least 25 minutes before reopening the pool.

*b. Diarrheal-stool contamination.* Raise the FAC to 20 mg/L and maintain this level for at least 12.75 hours before reopening the pool. In pool water that contains chlorine stabilizer such as cyanuric acid, the pH shall be lowered to 6.5, and the free chlorine residual shall be raised to 40 mg/L and maintained for at least 30 hours.

*c. Vomit contamination.* Raise the FAC to 2 mg/L and maintain this level for at least 25 minutes before reopening the pool.

*d. Blood contamination.* If blood contamination occurs, implement the proper water contamination response procedures. If the disinfectant is measured and found to be below the required minimum residual level, the operator will immediately close the affected water feature until the disinfectant residual is verified at or above the required minimum. If the disinfectant is at the appropriate level, there is no need to close the pool.

*e.* If the water in a brominated pool is contaminated by a formed stool, a diarrheal stool, vomit, or blood, add chlorine in an amount that will increase the free chlorine residual to the required level for the prescribed amount of time specified for the type of contamination. Adjust the bromine residual as necessary before reopening the pool.

**4–12. Surface contamination cleaning and disinfection**

*a.* If feces, vomit, or blood has contaminated a surface in an aquatic facility, limit access to the area until remediation procedures are completed.

*b.* Before disinfection, clean and remove all visible contamination with disposable cleaning products effective with regard to the type of contaminant present, the type of surface to be cleaned, and the contaminant's location within the facility.

*c.* Disinfect the contaminated area using 500 mg/L FAC for non-porous surfaces or 5,000 mg/L FAC for porous surfaces, as specified in table 4–2.

**Table 4–2. Bleach solution preparation and application**

Target FAC Concentration (ppm) <sup>1</sup>	Bleach Product Strength <sup>2, 3, 4</sup>		Minimum Wet Contact Time <sup>5</sup>	Surfaces <sup>6</sup>
	5.25 – 6 %	8.25%		
50	1 teaspoon per 1 gallon water—5 milliliters (ml) per 3.8 liters (L) water	½ teaspoon (2.3 ml) per 1 gallon water (3.8 L) water	1 minute	Floors; walls; sinks; showers; toilets; fixtures; whirlpool baths; furniture; toys; food contact surfaces
100	½ Tablespoon (7 ml) per 1 gallon (3.8 L) water	1 teaspoon (5 ml) per 1 gallon (3.8 L) water	30 seconds	
500	¼ cup (59 ml) per 1 gallon (3.8 L) water	1½ tablespoons (22 ml) per 1 gallon (3.8 L) water	1 minute	<b>Non-porous</b> surfaces contaminated by bodily excretions (vomit, feces, blood); diaper changing areas; MRSA control (shower shoes)
1000	1/3 cup (79 ml) per 1 gallon (3.8 L) water	3 tablespoons (44 ml) per 1 gallon (3.8 L) water	10 minutes	<b>Norovirus Response (non-porous surfaces):</b> tile floors; countertops; sinks; toilets
5000	1.5 cups (355 ml) per 1 gallon (3.8 L) water	1 cup (237 ml) per 1 gallon (3.8 L) water	10 minutes	<b>Porous surfaces:</b> decks, benches, floors, and walkways constructed of wood, concrete, stone, and other masonry— <ul style="list-style-type: none"> <li>• Contaminated by bodily excretions:</li> <li>• Norovirus Response</li> </ul>

<sup>1</sup> Parts per million (ppm) is equal to 1 milligram per liter (mg/L).

<sup>2</sup> Use only unscented, household liquid bleach; gel-type products and industrial-strength products (greater than 8.25% sodium hypochlorite) are not authorized for preparing disinfection solutions.

<sup>3</sup> The prescribed mixing formula assumes the lowest base strength of bleach product (specified in the column) is used. Products containing a higher base strength will result in a bleach solution concentration that is higher than the specified target for the formula. Use test paper to verify the final concentration of the prepared solution.

<sup>4</sup> Some products that are not EPA-registered, to include some generic and foreign brands, may contain a base sodium hypochlorite strength that is less than 5%. Products that have been opened previously and stored for 30 days or more may have a degraded base sodium hypochlorite strength that is less than 5%.

<sup>5</sup> For the desired disinfection to be achieved, the surface must remain wet for the specified length of time.

<sup>6</sup> Bleach will seriously damage textiles and other vulnerable surfaces (metal, for example).



**4-13. Measurement of chemical water quality**

*a.* Pool staff shall evaluate and document the chemical water quality of recreational water facilities as per appendix D. Preventive medicine/public health personnel will review these records as part of their weekly inspections and provide remedial sampling training to pool staff as requested or deemed necessary.

*b.* Determine chlorine residuals and pH using a test kit as described in paragraph 4-3 of this bulletin. Record chlorine residuals and pH determinations on DA Form 3164-R (Swimming Pool Operating Log).

(1) At swimming pools, the chlorine residual and pH are measured every 2 hours, at a minimum, during active pool operating hours.

(2) At wading pools, aquatic play features, spray pools, and spas, greater usage may require testing the water more frequently.

(3) Test the water 30-60 minutes before the facility opens.

(4) If the tests reveal the water quality does not meet the minimum requirements, do not open the facility until the water quality is brought into compliance. Follow the reporting and response procedures in the facility's emergency action plan (section V of this chapter).

(5) Measure the swimming pool water temperature at least twice each day, and record the temperature on DA Form 3164-R. Record the spa water temperature each time the residual chlorine and pH are measured.

*c.* As discussed in paragraph 2-26b of this bulletin, maintaining the proper pH level is critical to the effectiveness of the disinfectant.

(1) Maintain the pH of the pool water between values of 7.4 and 7.6.

(a) If the pH falls below 7.2, add alkaline substances such as sodium carbonate (soda ash) to the water to raise the pH to the proper level.

(b) If the pH is greater than 8.0, add sodium bisulfate or hydrochloric acid (muriatic acid) to reduce the pH value to the proper level.

(2) Carbon dioxide (CO<sub>2</sub>) gas may be used to lower the pH at pools using sodium hypochlorite or calcium hypochlorite.

(a) Pools using a water source with high alkalinity or hardness, and pools that use calcium hypochlorite should avoid using CO<sub>2</sub> as it will further raise the alkalinity of the water.

(b) Inject CO<sub>2</sub> into the recirculation pipe at the same point at which the pH adjustment solutions would normally be added. The recirculation pipe shall be of sufficient size and length to provide a minimum of 5 seconds of contact time prior to bather contact with the water.

*d.* Perform and document a test for alkalinity at least once weekly.

(1) Ensure the total alkalinity of the water in a swimming pool or spa is at least 50 mg/L, but not greater than 150 mg/L, as measured by the methyl-orange test. Alkalinity within this range of values helps to maintain the pH at proper levels.

(2) To reduce the corrosive action of low-alkalinity water or the scaling caused by high-alkalinity water, water in swimming pools and spas should be chemically balanced as determined by the Langelier Index (appendix G). For some pool or spa waters, the calcium bicarbonate content is very soluble. When calcium bicarbonate breaks down, it forms calcium carbonate, an

insoluble compound, which then forms scale on the inside of pipes, conduits, and other surfaces. Scale may—

(a) Appear as white or lightly-colored rough blotches on the walls of a swimming pool or spa.

(b) Form on the grains of sand-type filters and reduce filtration efficiency.

(c) Shorten filter runs.

e. If the water in a swimming pool or spa is low in calcium and magnesium, these minerals may leach out of the walls and bottoms of swimming pools and spas constructed of masonry materials.

f. Measure the cyanuric acid levels at least once a week if a chlorine cyanurate disinfectant is used. A test kit other than that used for the pH and FAC assessment is necessary to measure the cyanuric acid level (refer to subparagraph 4–3b(4)).

g. Retain all records for a minimum of two swimming seasons.

#### **4–14. Physical water quality**

a. Always maintain the water quality so that the bottom of the pool or spa is clearly visible when the water is undisturbed. If at any time the turbidity is such that the bottom of the pool or spa is not clearly visible, or when a Secchi disk placed at the deepest point is not clearly visible to an adult standing on the deck, close the facility until the water is clear enough for the bottom to be seen.

b. The temperature of spa water shall not exceed 104 °F and shall be monitored as specified in paragraph 4–3e.

#### **4–15. Preopening inspections**

a. Approximately 30 days prior to opening, knowledgeable representatives of preventive medicine/public health, DPW, the safety office, and DFMWR shall perform a thorough annual inspection of all swimming facilities and spas to ensure safe and healthful swimming and bathing.

b. At indoor facilities operated year-round, conduct the annual inspection at a specified time, preferably 30 days prior to the start of heavy seasonal use.

c. The following recreational water facilities must undergo a preopening inspection: facilities that have undergone renovations during which equipment has been changed/added; those where a change in operations has taken place (water venue was modified, for example); or any facility that has been closed longer than 30 days.

d. The inspected facility may not be opened until noted deficiencies have been corrected.

#### **4–16. Routine inspection**

a. Preventive medicine/public health personnel shall conduct weekly (routine) inspections of all recreational water facilities in active operation to determine whether a facility's sanitation and safety controls meet the minimum requirements of this bulletin. All recreational water inspections must be entered in the Environmental Health module of the Defense Occupational and Environmental Health Readiness System (DOEHRS), <https://doehrs-ih.csd.disa.mil/>. To

facilitate data entry, blank copies of the DOEHRS *Recreational Waters Survey* form, separated by venue type, may be downloaded from the DOEHRS Resource Page at <https://mesl.apgea.army.mil/mesl/doehrsResources/initialize.do>. Use of DA Form 7267-R (Checklist for Routine Inspection of Swimming Pools) is also authorized to conduct inspections; however, the form content does not match the DOEHRS *Recreational Waters Survey* form and may result in incomplete or inaccurate data entry. Inspection records shall be retained for at least 2 years.

*b.* More frequent inspections and concurrent bacteriological analysis shall be conducted if local conditions so dictate. Frequent inspections of recreational water facilities ensure that proper sanitation and safety controls are implemented and followed.

*c.* Special attention will be given to the following water quality parameters:

- (1) Disinfectant residual.
- (2) Cyanuric acid (if used).
- (3) pH.
- (4) ORP.
- (5) Turbidity.
- (6) Water temperature.

*d.* Any deficiencies identified during weekly inspections must be addressed with pool operators and corrected. The medical commander must be made aware of any recurring or major deficiencies that pose a direct threat to public health.

#### **4-17. Aquatic facility closure**

*a.* Aquatic facilities shall be maintained in safe condition during planned or seasonal closures.

*b.* Closing a facility for 7 days or less is considered a temporary closure. Closing it for longer than 7 days is considered a long-term closure.

*c.* The water in an outdoor aquatic facility closed for more than 7 days shall be drained, or an approved safety cover that meets the ASTM F1346-91 standard will be installed.

*d.* The water not drained from an aquatic facility closed for more than 7 days (that is, covered water) shall be recirculated and treated to ensure the water quality parameters meet the criteria of this bulletin.

*e.* The water in an aquatic facility closed for 7 days or less shall be recirculated and treated to ensure the water quality parameters meet the criteria of this bulletin.

*f.* Facilities closed for more than 7 days must meet all criteria in this bulletin before reopening.

*g.* When facilities are closed, even for short periods of time, their potable water sources will likely become stagnant. Ensure all potable water sources (including drinking fountains) are adequately flushed and disinfected prior to reopening the facility.

## Section II. Health Considerations in Natural Bathing Areas

### 4–18. Diseases

a. Natural bathing areas are unique because water quality is influenced by many factors such as wild animals, plants, sewage outfalls, and storm runoff.

(1) Early epidemiological studies have associated gastrointestinal illness with swimming in sewage-contaminated water. In some of these studies, typhoid fever and nonspecific enteritis were shown to be statistically related to swimming in water into which raw sewage had been discharged. In more recent epidemiological studies, swimming in natural bodies of water was found to be associated with outbreaks of shigellosis, salmonellosis, and viral infections caused by the Coxsackie A16 and B viruses, hepatitis A virus, and Norwalk agent virus.

(2) From 1948 through 1950, epidemiological studies were conducted by the U.S. Public Health Service to determine specifically what, if any, relationship exists between the water quality of natural bathing areas and the illnesses of bathers. These inconclusive studies tended to show that a higher incidence of disease (including gastroenteritis, respiratory disease, and infections of the eyes, ears, nose, and throat) was associated with swimming in water of poor bacterial quality.

(3) In the 1970s and 1980s, the USEPA undertook several epidemiological studies to gain better insight into the public health problems associated with swimming in natural bathing areas. These studies indicated that high gastrointestinal illness rates of swimmers were associated with high densities of fecal bacteria: *E. coli* and enterococci. Density values for total coliform bacteria showed little or no correlation with illness. These studies resulted in the proposal of new bacteriological standards for recreational waters.

(4) More recently, USEPA collaborated with CDC using rapid detection technology at fresh water and marine beaches in the United States and published updated water quality criteria in 2012 (see appendix A).

b. Table 4–3 shows the disease agents associated with swimming in untreated water (such as lakes, rivers, oceans) for reported WBDOs between 2005 and 2010.

**Table 4–3. Etiologic agents in recreational water-associated outbreaks (natural bathing areas), 2005-2010**

DISEASES	OUTBREAK OCCURRENCE		
	2005-2006	2007-2008	2009-2010
	n=19 (242 cases)	n=17 (471 cases)	n=12 (232 cases)
<i>Cryptosporidium</i> spp.	10.5%	11.8%	25.0%
<i>Plesimonas shigelloides</i>	--	5.9%	--
Schistosomes	--	23.5%	--
Norovirus	15.9%	17.6%	8.3%
<i>Shigella</i> spp.	15.8%	11.8%	8.3%
<i>E. coli</i>	15.8%	23.5%	25.0%
<i>Campylobacter</i>	--	--	8.3%
<i>Leptospira</i> spp.	10.5%	--	--

DISEASES	OUTBREAK OCCURRENCE		
	2005-2006	2007-2008	2009-2010
	n=19 (242 cases)	n=17 (471 cases)	n=12 (232 cases)
Multiple agents	--	5.9%	8.3%
Unidentified (includes suspected agents) and other agents	31.6%	17.6%	16.7%

#### 4–19. Water quality standards

a. Bathing in natural waters (such as streams, rivers, lakes, and tidal or salt waters) presents special problems. The sanitary quality of these waters cannot be controlled nearly as easily as in well-designed swimming pools. Site selection for these facilities is the most critical factor in maintaining good sanitary quality. Ensure bathing areas are free of the effects of point and nonpoint source discharges. Sources of potentially dangerous contamination of bathing or recreational waters are wastewater discharges from communities, industries, military installations, individual homes, marine craft, local animal populations, and waterfowl.

b. Bacteriological examination, as part of a rigorous sanitary survey, is essential for all areas and tributary watersheds considered for use as bathing or recreational areas. Use the water quality criteria discussed in paragraphs 4–20 and 4–21 to determine the acceptability of the site. The use of all natural bathing areas under installation control is subject to approval by the medical commander. Additional guidance for evaluating natural bathing or recreational areas may be available in specific state regulations/policies applicable to recreational water facilities.

c. Preventive medicine/public health personnel shall conduct sanitary surveys of natural bathing areas on a yearly basis, prior to each site's seasonal opening. See paragraph 4–23 for further information about sanitary surveys.

#### 4–20. Bacteriological indicators

a. *E. coli* and enterococci (a subgroup of fecal streptococci), the latter shown in figure 4–4, are considered the best indicators for gastroenteritis risk to swimmers in fresh water. Enterococci are considered the best health risk indicators for marine waters.

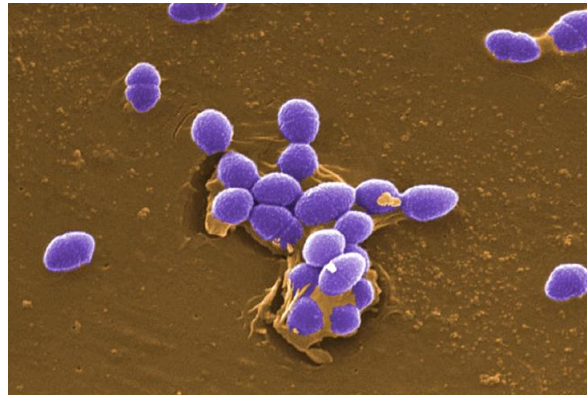

**Figure 4–4. Enterococci bacteria**

*b.* Using these indicator organisms, the USEPA created Beach Action Values (BAVs) which function as conservative, precautionary tools for making beach notification/closure decisions. These values differentiate water quality criteria (discharge permit requirements, for example) from beach health warnings. The BAVs are intended to be single sample guidance for issuing health warnings and are shown in table 4–4.

**Table 4–4. Beach Action Values**

Indicator	BAV (Units per 100 mL)
Enterococci (fresh and marine)	70
<i>E. coli</i> (fresh)	235

c. At a minimum, natural bathing areas shall be monitored weekly. Any single sample measuring above the BAV triggers a beach notification/closure that remains in effect until a repeat sample that measures below the BAV is collected. Repeat samples should be collected within 24 hours of the elevated sample.

d. Monitoring the natural bathing area after rainfall can provide a baseline of data to—

(1) Determine the extent to which runoff affects the quality of the bathing water.

(2) Establish the period of time required for bacterial levels to return to normal. This information can support decisions to close beaches.

#### **4–21. Physical water quality**

Clarity and visibility in the waters of natural bathing areas are very important. Water clarity will allow for—

a. Clear observation of swimmers by the lifeguards.

b. Visibility of the bottom at wadeable depths.

#### **4–22. Routine inspection**

a. Preventive medicine/public health personnel shall conduct weekly inspections, to include bacteriological collection and analysis, of all natural bathing areas in use. Inspections determine if the sanitary control and safety of these facilities meet or exceed the minimum requirements of this bulletin. More frequent inspections and concurrent bacteriological analyses shall be conducted when local conditions warrant.

b. Natural water samples are collected at least 25 feet from shore at a depth of 3 to 4 feet and in an area representative of the bathing water.

c. Additional information is collected regarding factors that may impact the water quality of natural bathing areas, to include the approximate amount of rainfall in the previous 24 hours, bather load at the time of sampling, presence of waterfowl, clarity of the water, and wind direction.

#### **4–23. Annual inspection/sanitary survey**

a. Preventive medicine/public health personnel shall conduct a sanitary survey at least yearly for all natural bathing areas. The survey—

(1) Must be conducted approximately 30 days prior to the area's opening.

(2) Examines safety hazards and potential sources of pollution (such as wastewater discharge or agricultural drainage) that could impact the swimming area.

b. The following factors influence the suitability of a natural bathing area:

(1) Location and volume of point and non-point source discharges and their chemical, bacterial, and physical characteristics. For example, sewage treatment plant and pump station

locations, industrial plant discharge points, agricultural drainage areas, and large populations of waterfowl can potentially impact natural bathing areas.

(a) No specific distance from point and non-point surface discharges to a bathing area will apply in all cases.

(b) An evaluation of the bacteriological and chemical effects of these discharges on the bathing area shall be included as part of this survey. Interpretation of these results determines if the discharges are significant.

(2) Volume and quality of the receiving water.

(3) Water depth and slope within the proposed bathing area.

(4) Water surface area.

(5) Tides (if applicable).

(6) Time of day and year, and weather conditions at the time of the survey.

(7) Thermal and salinity stratification.

(8) Effects of tributaries on the area.

(9) Water current.

(10) Prevailing winds.

(11) Other site-specific criteria that may apply.

(12) Submerged objects, sharp drop-offs, the condition and stability of the beach bottom, and the water depth in the diving area. Some natural bathing areas may be known to experience shifting sands after storm events. Evaluate such areas after storms to ensure patron safety.

c. The sanitary survey shall also include inspection of grounds, bathhouses, toilets, drinking water supply, sewage disposal, safety equipment, and signage, as appropriate.

#### **4-24. Cause for closure**

a. If a known waste contamination event (such as sewage bypass, ruptured sewer pipe, or other discharge) is expected to impact the bathing area's water quality, preventive medicine/public health personnel must recommend a beach closure. A beach closure may be decided upon without sample results confirming the pollution. However, factors such as currents, tides, and wind direction must be factored into the closure decision.

b. If a known or suspected contamination event prompts sampling of a bathing area, preventive medicine/public health personnel may recommend closure if the initial results exceed the standards (that is, prior to resample results).

c. Rainfall data may also be used to implement bathing area closures. Establish a baseline by collecting samples within 24 hours of a measurable rainfall event for at least one season. If the data show that bacterial levels are above the BAV 24 hours after a measurable rain event, the medical commander should recommend that the affected bathing area be closed following such rainfall events.

d. The natural bathing area shall be closed when requested by preventive medicine/public health personnel or for the following reasons:

(1) Obvious contamination of the beach.

(2) Bathing beach water quality does not meet bacteriological or physical standards.



(3) Inadequate lifeguards or safety equipment, inclement weather conditions, or other hazardous conditions.

### Section III. Safety Considerations in Pools and Spas

#### 4-25. Swimming pool drowning

*a.* Considering the number of people who use swimming pools each year, the swimming pool accident rate is low. In general, swimming pools are the safest place for people to swim; however, investigations of swimming pool injuries and drownings indicate that most could have been prevented had simple precautions been taken.

*b.* Lack of adequate supervision contributes to many cases of drowning in swimming pools. Fatal drowning remains the second leading cause of unintentional, injury-related death for children ages 1 to 14 years, often because there was no fence or barrier to prevent intrusion. Drownings have also been attributed to improper pool/facility design, faulty equipment, swimming alone, and, in some instances, the misconduct of swimmers themselves.

*c.* Some Soldiers may not be accomplished swimmers. Therefore, it is important for Soldiers to either receive survival swimming training according to Training Circular (TC) No. 21-21 or swim only when accompanied by an able swimmer in approved locations where qualified lifeguards are on duty. If not mandated, survival swimming training is highly encouraged for those units whose mission requires exposure to water hazards. Swimming should occur only in approved locations during daylight hours or at adequately lit facilities.

#### 4-26. Swimming pool injuries

*a.* All injuries sustained while using a recreational water facility and which require medical treatment shall be reported to the safety office and preventive medicine/public health personnel. Medical treatment includes treatment administered by physicians, hospital staff, or emergency medical personnel. Notification must be made within 1 week of occurrence, including information on the victim, type of injury, treatment, outcome, and injury circumstances. Serious injuries such as drowning; any event requiring resuscitation; head or spinal injuries; or poisoning/asphyxiation from gaseous or solid disinfectants must be reported immediately up the established chain of command. This includes the garrison and installation commands, the Army Safety Center, and the higher headquarters of the operating facility (IMCOM G-9/DFMWR, for example).

*b.* It has been estimated that 10 percent of all spinal cord injuries are attributable to diving into water. In addition, the CPSC estimates that 13,000 diving board-related injuries occur annually and are of a sufficiently serious nature to involve a hospital emergency room. The leading causes of pool injuries are—

- (1) Striking the bottom or side of the swimming pool when diving into water that is too shallow.
- (2) Using a swimming pool slide.
- (3) Colliding with objects in the pool, such as protruding water pipes and ladders.

- c. Other common factors identified as leading to swimming pool injuries are—
- (1) No qualified person supervising the swimming pool area.
  - (2) No signs posted to warn of potential dangers.
  - (3) Absent, improperly marked, or improperly placed depth markers.
  - (4) Occurrences of “shallow water blackout”—the loss of consciousness under water—are often caused by swimmers hyperventilating to increase the amount of time they can hold their breath under water. This practice is prohibited.
- d. An analysis of persons who received spinal cord injuries from diving or sliding head first into a swimming pool noted that the victim is usually an 18- to 20-year-old male, 6 feet tall, over 175 pounds, with no formal diving training. This profile should be publicized to make young Soldiers particularly wary of the dangers that exist.
- e. Since it increases the risk of injury, alcohol is incompatible with safe swimming. Alcohol is not permitted at recreational water facilities.
- f. Lightning presents a potentially dangerous situation for outdoor recreational water facility patrons. Water activities must remain suspended until 30 minutes after the last thunder is heard. Relying solely on lightning detectors is not recommended since the performance of a particular device may not have been verified.

#### **4–27. Chemical hazards**

- a. An emerging focus of concern at aquatic facilities is the risk of chemical injury from the improper handling of pool chemicals. Chemicals can become sources of illness/injury if they are not properly handled or if water quality and ventilation are poor. Recent cases have been linked to chemical overfeed, improper pool chemistry, and excessive chloramines.
- b. There are three primary routes of chemical exposure from pools and spas:
- (1) *Ingestion.*
    - (a) Estimates show children ingest more water than adults do; men ingest more than women, and boys ingest more than girls.
    - (b) Experienced swimmers (such as competitive swimmers) tend to ingest less water than less-experienced swimmers.
    - (c) Extensive direct contact (that is, full body immersion) involving swimming or diving presents a significantly higher risk of swallowing pool water.
  - (2) *Inhalation.*
    - (a) Swimmers inhale volatile or aerosolized solutes from the atmosphere directly above the surface of the water where solutes are concentrated. The amount of air inhaled depends upon the intensity of swimmers’ efforts and the amount of time spent in the water.
    - (b) Indoor pools have higher levels of volatiles present than outdoor pools.
  - (3) *Dermal contact and absorption.*
    - (a) Certain chemicals, such as chloramines, can directly impact the skin, eyes, and mucous membranes.
    - (b) Other chemicals may be absorbed through the skin into the body. The quantity absorbed depends on a number of factors, including the length of time a swimmer is in contact with the water, the water temperature, and the chemical concentration.

**4–28. Source of chemicals**

*a.* The presence of some chemicals in pools and spas can be attributed to the water used to fill the facilities. If a municipal water supply is used, DBPs, lime and alkalis, phosphates, or monochloramines (if the water supply is chlorinated) may be present.

*b.* Swimmers excrete nitrogen compounds (such as urine, sweat) that react with the free disinfectant, producing several byproducts.

*c.* Chemicals are added to recreational water facilities to ensure a safe swimming environment.

(1) Disinfectants are added to pools and spas to inactivate any microorganisms that could harm swimmers.

(2) Chemicals are added to pools to correct the pH when it is not within the range of 7.2 to 7.8.

(3) Swimming facilities may add coagulants to increase filtration effectiveness.

*d.* The DBPs are formed as a result of the disinfectant reacting with organics in the pool water. This is a growing concern since recent studies have shown DBPs may cause asthma and respiratory irritation in swimmers.

(1) The DBP formation depends on a number of factors, including precursor concentration, residual disinfectant level, water temperature, and pH. Trihalomethanes (THMs) and haloacetic acids (HAAs) comprise the greatest concentration of DBPs in pools and spas.

(2) Since DBPs are volatiles, they may be present not only in the pool water but also in the atmosphere above the water surface. The quantity of DBPs volatilized above the water is a function of DBP concentration in the pool, water temperature, and the amount of splashing. Poor ventilation and air circulation in the pool area also increase the concentration of DBPs in the air above the pool.

(3) Inhalation and skin absorption account for the greatest uptake of DBPs, but ingestion of water may also contribute. Proper ventilation, frequent dilution of pool water with fresh water, and a properly balanced pool will minimize swimmers' exposure to DBPs.

*e.* Chloramines are not considered health hazards in outdoor swimming pools. However, they can reach dangerous concentrations in indoor pools, posing a substantial health risk. High concentrations cause acute eye and respiratory tract irritation and may contribute to asthma. Chloramine-related outbreaks are thought to be common but are seldom reported.

**4–29. Spa drowning and injury**

*a.* A 2008 study of emergency department visits in the U.S. between 1990 and 2007 (Alhaji et al.) revealed that injuries to approximately 4800 people each year involved the recreational use of hot tubs, spas and whirlpools. The most severe injuries were predominantly seen in pediatric populations and included body entrapment, hair entanglement, disembowelment, and drowning. In 2013, the CPSC reported an estimated 5100 pool- or spa-related submersion injuries occurred each year between 2008 and 2012 with an estimated 3 percent of occurrences involving spas. The CPSC further reported 39 cases of circulation/suction entrapments during the same period with 33 percent of victims associated with a spa; the majority of victims were under the age of 15.

b. Implementation of voluntary standards for drain covers in swimming pools, hot tubs, whirlpools and spas was recommended by the CPSC in 1982 to reduce hazards caused by suction. In 2007 the VGB Act mandated all new and existing swimming pool and spa drain covers comply with the ASME/ANSI A112.19.9M-1987 standard by December 2008.

c. Other reported injuries are related to slips and falls that occur while a bather is entering or exiting a spa. Installation of slip-resistant surfaces in and around the spa is recommended to reduce the hazard.

#### **4–30. Water temperature of spas**

a. The temperature of spa water can cause injury or even death. Maintain spas at or below 104 °F, as there are no physiological benefits to operating at temperatures above this value.

b. When a person is submerged shoulder-deep in spa water, only the head, neck and upper portions of the shoulders are available to dissipate the heat generated by body metabolism. If the deep body temperature reaches or exceeds 104 °F, serious health consequences may result.

c. Evidence shows that exposure to the elevated temperatures of a spa can have a damaging effect to the developing fetus; therefore, pregnant women should not use spas. The following warning shall be posted on all spa entrance signage: *“Potential risk of birth defects and miscarriages is associated with maternal hyperthermia, especially during the first 12 weeks of pregnancy. Heat exposure to the fetus later in pregnancy should be kept to a minimum to avoid maternal hyperthermia.”* Additional information regarding the risks associated with high water temperature is provided in the MAHC Annex, Section 5.7.4.7.2.

d. Persons using spas with high water temperatures may experience drowsiness followed by unconsciousness and possible drowning. Because alcohol also relaxes the bather, the risk of drowning in a spa is heightened significantly if alcoholic beverages are consumed before or during spa use.

e. Young children are more susceptible to heat injury, such as overheating, when they are exposed to elevated spa water temperatures. As a result, the CDC recommends excluding children ages 5 years and younger from entering a spa, whether or not they are accompanied by an adult. Refer to <http://www.cdc.gov/healthywater/swimming/resources/operating-public-hot-tubs-factsheet.html> for additional information.

f. Guidance procedures for safe use must be posted at the entrance of every spa. Appendix C provides recommendations for safe use.

#### **4–31. Supervision of swimming**

a. Lifeguards and aquatic staff shall maintain certification and training requirements as specified in AR 215–1, to include bloodborne pathogen training specified in 29 CFR 1910.1030.

b. At least one person responsible for maintaining pool balance and adjusting chemicals must hold a valid CPO or AFO certificate. Such persons do not have to be constantly available on the premises but must be available on-call.

c. Lifesaving measures and equipment shall be according to this bulletin, to AR 215–1, and/or current nationally recognized standards, whichever is most stringent.

*d.* Surveillance duties (including shifts and breaks) shall be implemented according to AR 215–1.

*e.* Locate lifeguards in positions from which they can observe their entire assigned swimming area.

*f.* Additional lifeguards may be needed during special events, instructional classes, or if play features, a zero-depth pool entry, or large aquatic areas are present. Site-specific conditions, to include bather occupancy loads, will determine the actual number of lifeguards required to adequately control a pool.

*g.* Each lifeguard must be able to survey his or her assigned area every 10 seconds and be able to respond to a distressed swimmer within 20 seconds. If this is not possible, additional lifeguards are needed.

#### **4–32. Lifesaving equipment**

*a.* Each pool must be furnished with the lifeguard and lifesaving equipment described in AR 215–1.

*b.* In addition, a first-aid station equipped with the following will be provided:

(1) A first-aid kit meeting the requirements of OSHA standard 29 CFR 1910.151, Medical services and first aid.

(*a*) The decision to stock aspirin in first aid kits to provide to patrons must be made locally among pool management, the safety officer, the staff judge advocate, and the medical commander/preventive medicine/public health authority.

(*b*) Potential liability issues involved with dispensing aspirin to patrons should be weighed against the life-saving benefits of aspirin in cases of suspected heart attack. If aspirin is stocked in first aid kits, a minimal number of single use packages, rather than bottles, should be stocked.

(2) A bloodborne pathogen personal protective equipment (PPE) kit meeting the requirements of OSHA standard 29 CFR 1910.1030 (d)(3)(i).

(3) A blanket and stretcher.

(4) An automated external defibrillator (AED).

*c.* Spas in a standalone location (not co-located with a pool) must be equipped with the following lifesaving equipment:

(1) A first aid kit meeting the requirements of OSHA standard 29 CFR 1910.151.

(2) A bloodborne pathogen PPE kit meeting the requirements of OSHA standard 29 CFR 1910.1030 (d)(3)(i).

(3) A standard backboard made to the specifications of the American Red Cross.

(4) A working clock clearly visible from the spa.

#### **4–33. Location of lifesaving equipment**

*a.* Mount lifesaving equipment in conspicuous places and distribute it around the pool deck at lifeguard chairs or elsewhere. Equipment must be readily accessible and kept in good repair and operating condition; instructions for equipment function should be visible. Do not permit

swimmers or other unauthorized personnel to tamper with or use equipment for any purpose other than its intended use.

*b.* Provide a toll-free telephone at each bathing facility for emergency use. Restrict public access to the telephone in order to ensure its availability in case of an emergency. Consider installing a dedicated, 911 emergency-restricted land-line phone.

*c.* The telephone must be located within 200 feet of the pool entrance with the location specified on the pool rules sign. The telephone must be checked daily prior to opening to ensure it is working properly.

*d.* Post emergency contact information at all telephones designated for emergency use, regardless of whether or not the phone provides 911-direct access. Emergency information shall include the numbers of the nearest ambulance service, hospital, military police, fire rescue unit, safety office, and DPW or contracted emergency assistance.

#### **Section IV. Safety Considerations in Natural Bathing Areas**

##### **4–34. Drowning and injury**

*a.* Drowning is a significant safety issue at natural bathing areas. The percentage of drownings in natural water settings increases with age; the majority of drowning victims are over 15 years of age.

*b.* Safety at natural bathing facilities depends upon the ability of swimmers to swim, to take care of themselves under ordinary conditions, and to recognize and avoid hazardous water conditions and practices.

##### **4–35. Guidelines for safe natural bathing areas**

*a.* To provide a reasonably safe natural bathing area—

- (1) Promote the prevention of accidents and injuries.
- (2) Supervise the swimmers.
- (3) Keep suitable rescue equipment readily available.
- (4) Ensure nonhazardous levels of chemical and biological contaminants.

*b.* The bottom of the natural bathing area should—

- (1) Slope gently and uniformly toward deep water.
- (2) Have no holes or sudden step-offs.
- (3) Be free of hidden or submerged obstructions such as rocks, stumps, snags, and sunken logs.
- (4) Be composed of firm sand, small-sized gravel, or shale.
- (5) Have no silt, quicksand, shell patches, sharp and broken rock, or debris in depths of 5 feet or less.

*c.* Clearly define and mark swimming areas for various classes of swimmers.

*d.* Permit no watercraft in the swimming areas other than those used for lifesaving.

*e.* Mark the outermost limits of swimming areas at regular intervals with buoys, or similar devices, bearing signs warning all watercraft to keep out.

*f.* Post signs on offshore floats or rafts indicating whether or not diving is permitted.

g. Post signs at marine bathing beaches to warn swimmers/bathers of the possible presence of harmful aquatic life, such as jellyfish.

h. Keep beach areas clean and well-raked at all times.

i. Prohibit smoking on the beach. Designate smoking areas near the beach, and provide proper waste receptacles.

j. Prohibit bottles and cans of food and drink on the beach.

k. Prohibit picnicking on the beach. Designate picnic areas near the beach, and provide proper waste receptacles.

l. Prohibit alcohol on the beach.

m. The DFMWR must post information at natural bathing areas throughout the recreational season to advise the public about water conditions and hazards. In addition to signs, beach warning flags shall be posted to inform the public of advisories and warn of rip currents and weather-related hazards.

n. The DFMWR must post a sign at natural bathing areas throughout the recreational season to provide patrons with water quality information. Wording should be similar to the following:

**WATER QUALITY INFORMATION**  
 Bacterial levels may be elevated for 24–48 hours after heavy rain events due to surface runoff. Full-body water contact is not recommended under those conditions.

o. If a natural bathing area is closed due to bacteriological exceedances, DFMWR must post a sign to inform the public that the water quality standard has been exceeded. Wording should be similar to the following:

**WATER QUALITY ADVISORY**  
 Bacterial levels currently exceed applicable standards. Children, the elderly, and those in ill health are advised not to swim. Full-body water contact may cause illness.

p. Recent research has shown MRSA may be present in the sand and water of natural bathing areas. Post a sign where patrons will see it upon entry to the area. Wording should be similar to the following:

**To prevent the risk of illness—**

1. Cover any open cuts or scrapes before playing in the sand, to reduce the risk of infection.
2. Shower after swimming, and wash off all sand.

**4-36. Supervision of swimming**

*a.* Whenever a natural bathing area is open for use, at least two qualified lifeguards shall be on duty. One of the lifeguards shall be stationed in a lifeguard tower or elevated chair. Ensure elevated lifeguard chairs are—

(1) Provided at a rate of one lifeguard tower or elevated chair for every 200 feet of beach or fraction thereof.

(2) Constructed and strategically located in such a manner to provide complete surveillance of all swimmers, bathers, and divers within assigned swimming areas.

(3) Just high enough to give lifeguards a complete and unobstructed view of the bathing and beach area for which they are responsible.

*b.* Provide one lifeguard in a boat for every 1,000 feet of beach.

*c.* When on duty, lifeguards may not perform any other duties, and they may not be in the water except in the line of duty.

*d.* Lifeguards must be certified according to AR 215-1 specifications.

*e.* Identify on-duty lifeguards by means of distinguishing apparel, emblems, or signs.

*f.* Equip each lifeguard with a whistle or megaphone, an umbrella, sunglasses, a hat that does not hinder peripheral vision, and sunscreen (sun protection factor (SPF) 15, at a minimum).

*g.* Surveillance duties (including shifts and breaks) shall be implemented according to AR 215-1.

*h.* Natural bathing areas not adequately staffed with lifeguards shall have signage posted warning that swimming is at one's own risk when no lifeguard is present.

**4-37. Lifesaving equipment**

*a.* In natural bathing areas, provide lifeguards with the following lifesaving equipment:

(1) A light surfboard, kept in the immediate vicinity of each lifeguard tower.

(2) One or more throwing lines with an attached ring buoy. The throwing line shall be—

(a) Three-sixteenths of an inch in diameter with a length of 75 feet.

(b) Attached to a 15-inch maximum diameter ring buoy.

(c) Located at each lifeguard tower.

(3) A swimming rescue can or tube worn by each lifeguard. This device is towed out to a victim by a lifeguard to provide buoyancy for a victim and to assist the lifeguard in bringing the victim to safety.

*b.* In addition to the equipment listed above, provide the following:

(1) A properly equipped first-aid station (paragraph 4-33b) and readily available telephone.

(2) A standard backboard made to the specifications of the American Red Cross.

(3) An AED.

(4) At least one rescue flotation device for each lifeguard on duty.

(5) Mask(s) and snorkel(s) readily accessible for underwater search and rescue as appropriate.

(6) Binoculars readily accessible in the beach area and in each main tower and emergency vehicle.



- (7) Marker buoy(s) readily accessible for submerged victim search and rescue.
- (8) Swim fins readily accessible to lifeguards for rescue purposes, as appropriate, according to local conditions.
- c. Position some of the lifesaving equipment at each lifeguard tower or elevated chair. In addition, keep extra equipment at a central point where it is readily available.

## Section V. Emergency Planning

### 4-38. Emergency planning

Managers of recreational water facilities shall maintain an operating procedures manual onsite containing emergency response and communication information.

a. Develop an Emergency Action Plan (EAP) similar to those outlined by the MAHC, American Red Cross, Young Men's Christian Association (YMCA<sup>®</sup>) or to comparable aquatic safety organization manuals. (YMCA<sup>®</sup> is a registered trademark of National Council of Young Men's Christian Associations of the United States of America, Chicago, IL.) At a minimum, the plan must include—

- (1) A diagram of the facility.
- (2) Names and telephone numbers of police, fire, ambulance, and other emergency service personnel.
- (3) Location of the first-aid kit and other rescue equipment.
- (4) Emergency response procedures for an accidental chemical release.
- (5) Anticipated emergency scenarios and response procedures.

b. The plan should also include basic steps for administering cardiopulmonary resuscitation (CPR)/AED/first aid, along with missing person and contamination response procedures. Where applicable, the plan should also include "Drill Procedures for Emergency Situations" and a "Water Rescue and Injury Emergency Plan," as well as other emergency plans and safety programs.

c. The EAP must be included in the orientation for newly-hired lifeguards and must be practiced at least once prior to their performing primary duties.

d. The EAP must be reviewed at least annually and updated as necessary. It must include the training frequency and documentation of those who have been trained. This training should include—

- (1) In-service training or onsite rescue training/drills conducted according to AR 215-1 specifications.
- (2) Water rescue competency tests every 10-12 weeks (successful completion required).
- (3) Emergency drill procedures conducted at least quarterly to ensure that—
  - (a) All lifeguards are familiar with their responsibilities and procedures outlined in the EAP.
  - (b) Communication procedures are operative.
  - (c) Rescue equipment is operational.

*e.* The accidental chemical release procedures must include actions for response and clean-up, staff training requirements for these procedures, and a list of equipment and supplies for clean-up. The availability of equipment and supplies for clean-up must be verified by pool staff at least weekly.

*f.* Facility evacuation procedures must also be developed as part of the E A P. At a minimum, the evacuation procedures will include actions to be taken in the event of a drowning, serious illness/injury, chemical handling accident, weather emergency, and any other applicable serious incident(s). Roles and responsibilities for all staff must be defined within the evacuation protocol.

*g.* A Communication Plan must be developed for aquatic facilities. The purpose of this plan is to facilitate activation of internal emergency response centers and/or community 911 as necessary. At a minimum, this plan must include—

(1) Readily accessible, appropriate communication devices (such as telephones, call boxes, mobile devices) and instructions on their use (such as established codes for radios/walkie-talkies).

(2) Signage. Figure 4–5 illustrates the 16 most common lifeguard hand signals.

(3) Procedures to be followed during staffed and unstaffed time periods.

(4) Acceptable alternative means of communication during loss of power.

(5) Training of all personnel.

*h.* A Communication Plan for natural bathing areas must establish rules for using available or designated forms of communication. If radios or walkie-talkies are used for communication, ensure the codes/means of communication are documented and understood by all recreational water facility staff/lifeguards. When whistles are used, the plan must specify the following:

(1) *One short blast* on a whistle is used when a lifeguard wants the attention of a swimmer.

(2) *One long blast* is a signal used to clear the water of swimmers.

(3) *Two short blasts* on a whistle are used when a lifeguard wants the attention of another lifeguard.

(4) *Three long blasts* on a whistle are the signal for an emergency. All lifeguards present, whether on break or secondary duty, are to report immediately to the designated location specified in the EAP.

*i.* As part of the EAP, an inclement weather protocol must be developed to address localized weather events that could affect the facility's operations. It will include training required for employees, evacuation procedures, and guidelines for re-opening a facility after closure due to a weather event (such as lightning, tornadoes, and so forth).

*j.* If an emergency occurs (such as a person needing rescue)—

(1) Follow all established procedures and training principles.

(2) Report the incident according to paragraph 4–27a and ensure submission of the proper documentation through the established chain of command.

(3) Lifeguards who have participated in a high-stress rescue shall be debriefed, and a determination shall be made as to whether or not post-traumatic stress counseling is appropriate. In the event of a fatality, this counseling is mandatory.

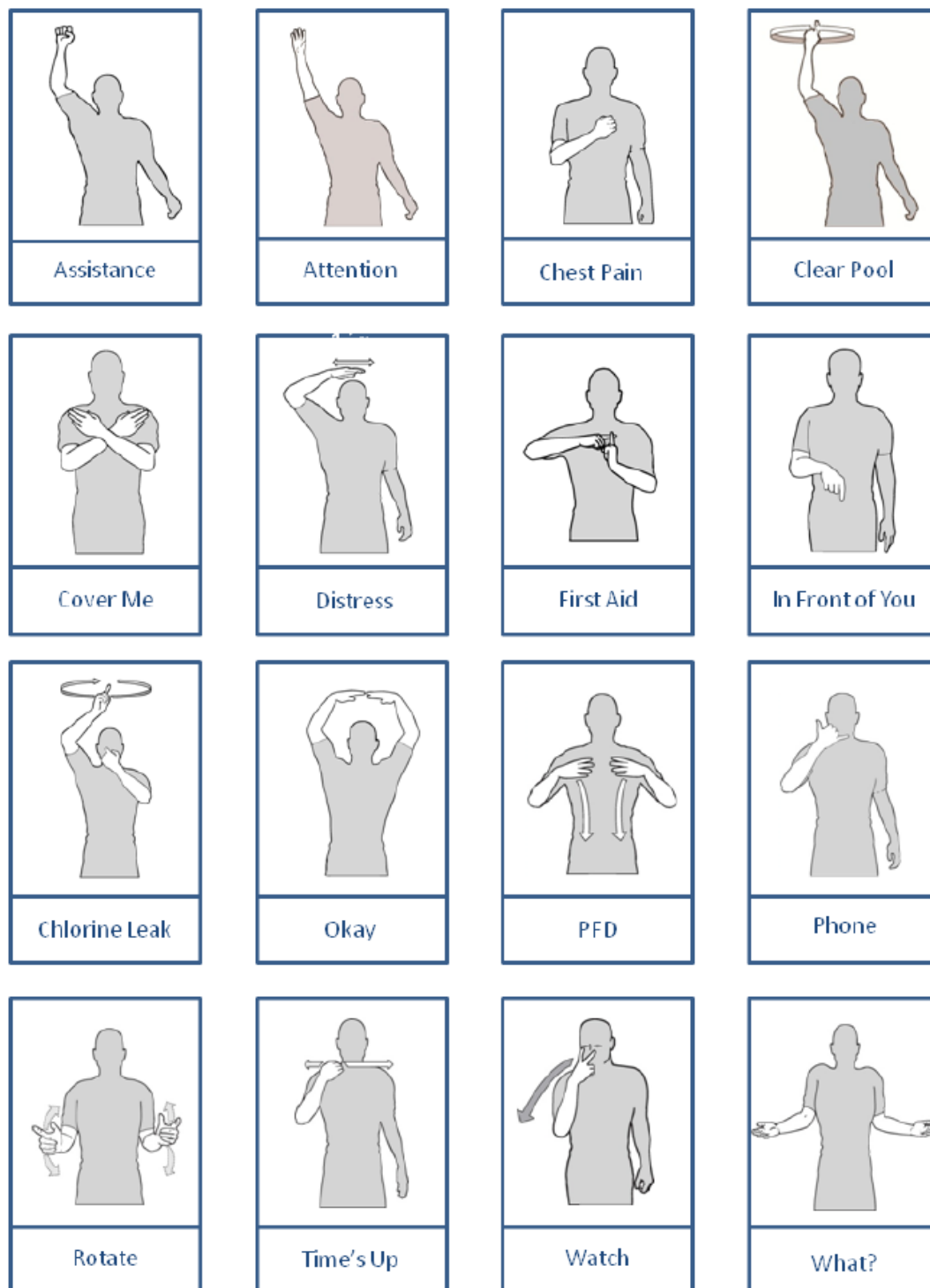

Figure 4-5. Common lifeguard hand signals

**APPENDIX A****REFERENCES**

---

**Section I****Required Publications**

Army regulations, the Department of the Army pamphlet, and technical bulletins, medical are available online from the U.S. Army Publishing Directorate Web site at <http://www.apd.army.mil/>. Except as noted below, American National Standards Institute standards are available online from the ANSI Web site at <http://www.ansi.org/>; Codes of Federal Regulations are available online from the Electronic Code of Federal Regulations Web site at <http://www.ecfr.gov/>; and U.S. Codes are available online from the Government Printing Office Federal Digital System Web site at <http://www.gpo.gov/> or the Office of the Law Revision Counsel Web site at <http://uscode.house.gov/>.

**AR 11–34**

The Army Respiratory Protection Program (Cited in para E–14*e*.)

**AR 40–5**

Preventive Medicine (Cited in paras 1–5 and 2–64*b*.)

**AR 215–1**

Military Morale, Welfare, and Recreation Programs and Nonappropriated Fund Instrumentalities (Cited in paras 4–32*a*, 4–32*c*, 4–32*d*, 4–33*a*, 4–37*d*, 4–37*g*, and 4–39*d*(1).)

**AR 385–10**

The Army Safety Program (Cited in para 2–62*a*.)

**DA Pam 40–11**

Preventive Medicine (Cited in para 1–5.)

**DA PAM 385-26**

The Army Electrical Safety Program (Cited in paras 2–62*a* and 2–62*b*(1).)

**TB MED 530**

Tri-Service Food Code (Cited in paras 2–64*b* and 3–5*b*.)

**TC No. 21–21**

Water Survival Training (Cited in para 4–26*c*.) [http://armypubs.army.mil/doctrine/tc\\_1.html](http://armypubs.army.mil/doctrine/tc_1.html)

**TM 5-662**

Swimming Pool Operations and Maintenance (Cited in paras 1-1c, 1-4, 2-26a, 2-26d(2), 2-46h, 2-50b, 2-51c(3), 4-1a, and B-1d(1).)  
[http://www.wbdg.org/ccb/ARMYCOE/COETM/tm\\_5\\_662.pdf](http://www.wbdg.org/ccb/ARMYCOE/COETM/tm_5_662.pdf)

**ANSI/APSP-1-2003** (see also ANSI/NSPI-1-2003)

Standard for Public Swimming Pools (Cited in paras 2-9e, 2-12a, 2-20a, and 2-12d.)  
<http://www.apsp.org>

**ANSI/ASHRAE Standard 62.1-2010**

Ventilation for Acceptable Indoor Air Quality (Cited in para 2-60f.)  
<http://ashrae.org/standards-research--technology/standards--guidelines>

**ANSI/ASSE 1001-2008**

Performance Requirements for Atmospheric Type Vacuum Breakers (Cited in para 2-15c(2).)

**ANSI/ASSE 1013-2011**

Performance Requirements for Reduced Pressure Principle Backflow Preventers and Reduced Pressure Principle Fire Protection Backflow Preventers (Cited in para 2-15c(4).)

**ANSI/ASSE 1020-2004**

Performance Requirements for Pressure Vacuum Breaker Assembly (Cited in para 2-15c(3).)

**ANSI/NSPI-1-2003** (also see ANSI/APSP-1-2003)

Public Swimming Pools (Cited in para 2-9e.)

**APHA/AWWA/WEF**

Standard Methods for the Examination of Water and Wastewater (Cited in paras 4-4c, 4-5a(2), 4-5b(3), and 4-6f(2).) <http://www.standardmethods.org/>

**ASME A112.1.2-2012**

Air Gaps in Plumbing Systems (for Plumbing Fixtures and Water-Connected Receptors) (Cited in para 2-15c(1).) <http://global.ihs.com>

**ASME A112.19.8 2009 (with addenda)**

Suction Fittings for Use in Swimming Pools, Wading Pools, Spas, and Hot Tubs (Cited in paras 2-37g, 2-37i, and 2-37l.)  
<http://global.ihs.com>

**ASME A112.19.17-2010**

Manufactured Safety Vacuum Release Systems (SVRS) for Residential and Commercial Swimming Pool, Spa, Hot Tub, and Wading Pool Suction Systems (Cited in para 2-37j(1).)

<http://global.ihs.com>

**ASTM F1159-11**

Standard Practice for Design and Manufacture of Patron Directed, Artificial Climbing Walls, Dry Slide, Coin Operated and Purposeful Water Immersion Amusement Rides and Devices and Air-Supported Structures (Cited in para 2–9*b.*) <http://www.astm.org/Standards/F1159.htm>

**ASTM F1346-91 (2010)**

Standard Performance Specification for Safety Covers and Labeling Requirements for All Covers for Swimming Pools, Spas and Hot Tubs (Cited in para 4–18*c.*)  
<http://www.astm.org/Standards/F1346.htm>

**ASTM F2387-04 (2012)**

Standard Specification for Manufactured Safety Vacuum Release Systems (SVRS) for Swimming Pools, Spas and Hot Tubs (Cited in para 2–37*j*(1).)  
<http://www.astm.org/Standards/F2387.htm>

**ATP 5-19**

Risk Management

**AWWA C511-07**

Reduced-Pressure Principal Backflow Prevention Assembly (Cited in para 2–15*c*(4).)  
<http://www.awwa.org/publications/>

**CDC**

Model Aquatic Health Code: Fecal/Blood/Vomit Contamination Response; Ventilation and Air Quality; and Risk Management/Safety Code and Annex Modules (Cited in para 4–9.)  
<http://www.cdc.gov/healthywater/swimming/pools/mahc/structure-content/>

**CDC MMWR**

Guidelines for Environmental Infection Control in Health-Care Facilities, vol /52(RR-10);20–21 (Cited in para 2–8*d.*)  
<http://www.cdc.gov/mmwr/PDF/rr/rr5210.pdf>

**EPA 815-R-99-013**

Disinfection Profiling and Benchmarking Guidance Manual (Cited in para 4–11*a*(4).)  
<http://www.epa.gov>

**EPA 820-F-12-058**

Recreational Water Quality Criteria (Cited in para 4–20*b.*)  
<http://water.epa.gov/scitech/swguidance/standards/criteria/health/recreation/upload/RWQC2012.pdf>

**International Fire Code 2012** (Cited in para 2–60*i*.)

<http://www.iccsafe.org/Pages/default.aspx>

**International Mechanical Code 2012** (Cited in para 2–60*i*.)

<http://www.iccsafe.org/Pages/default.aspx>

**NFPA 70®**

National Electrical Code® (NEC®); Article 680, Swimming Pools, Fountains, and Similar Installations (Cited in paras 2–62*a* and 2–62*b*(1).)

<http://www.nfpa.org/catalog>

**NFPA 70E®**

Standard for Electrical Safety in the Workplace®, 2015 Edition (Cited in para 2–62*a*.)

<http://www.nfpa.org/catalog/>

**NSF/ANSI Standard 50-2008**

Equipment for Swimming Pools, Spas, Hot Tubs and Other Recreational Water Facilities (Cited in paras 2–24*f*(1), 2–30*e*, 2–31*e*, and 2–46*g*.)

[http://standards.nsf.org/apps/group\\_public/download.php/3346/50i54r1%20Annex%20A%20and%20Section%203.pdf](http://standards.nsf.org/apps/group_public/download.php/3346/50i54r1%20Annex%20A%20and%20Section%203.pdf)

**NSPF® Aquatic Play Feature Handbook** (Cited in para 2–4.)

<http://www.nspf.org/en/home.aspx>

**NSPF® Pool & Spa Operator Handbook** (Cited in para 2–53.)

<http://www.nspf.org/en/home.aspx>

**UFC 3–230–02**

Operation and Maintenance: Water Supply Systems (Cited in para 2–46*h*.)

[http://www.wbdg.org/ccb/DOD/UFC/ufc\\_3\\_230\\_02.pdf](http://www.wbdg.org/ccb/DOD/UFC/ufc_3_230_02.pdf)

**UFC 3–530–1, with Change 3**

Design: Interior, Exterior Lighting and Controls (Cited in para 2–61*a*.)

[http://www.wbdg.org/ccb/DOD/UFC/ufc\\_3\\_530\\_01.pdf](http://www.wbdg.org/ccb/DOD/UFC/ufc_3_530_01.pdf)

**UFC 4-510-1, with Change 1**

Design: Military Medical Facilities (Cited in para 2-8*c*.)

[http://www.wbdg.org/ccb/DOD/UFC/ufc\\_4\\_501\\_01.pdf](http://www.wbdg.org/ccb/DOD/UFC/ufc_4_501_01.pdf)

**16 CFR 1207.5**

Safety Standards for Swimming Pool Slides – Design

**28 CFR 35.151 and 28 CFR Part 36 Subpart D**

2010 ADA Standards for Accessible Design (Cited in para 4–1*e*.)

**29 CFR 1910.134**

Respiratory Protection (Cited in para E–14*e*.)

**29 CFR 1910.151**

Medical Services and First Aid (Cited in paras 4–33*b*(1) and 4–33*c*(1).)

**29 CFR 1910.1030**

Bloodborne Pathogens (Cited in paras 4–33*b*(2) and 4–33*c*(2).)

**40 CFR 141.74**

Analytical and Monitoring Requirements (Cited in para 4–5*a*(1).)

**69 FR 44084**

Americans with Disabilities Act (ADA) Accessibility Guidelines for Buildings and Facilities;  
Architectural Barriers Act (ABA) Accessibility Guidelines (Cited in para 2–9*d*.)

<http://www.gpo.gov>

**15 USC 2051–2089**

Consumer Product Safety Act (Chapter 47) (Cited in para 2–22*a*.)

**15 USC 8001**

Pool and Spa Safety (Chapter 106) (Cited in para 2–36*f*.)

**USA SWIMMING**

2013 USA Swimming Rulebook (Cited in para 2–14*g*.)

[http://www.usaswimming.org/\\_.../2013%20Rule%20Book.pdf](http://www.usaswimming.org/_.../2013%20Rule%20Book.pdf)

**Section II**

**Related Publications**

A related publication is a source of additional information. The user does not have to read it to understand this publication. Army regulations and the technical bulletin, medical are available online from the U.S. Army Publishing Directorate Web site at <http://www.apd.army.mil/>. Except as noted below, American National Standards Institute standards are available online from the ANSI Web site at <http://www.ansi.org/>; U.S. Environmental Protection Agency standards are available online from the USEPA Web site at <http://www.epa.gov>. American Red Cross documents are available online at <http://www.redcross.org/>. Centers for Disease Control and Prevention Morbidity and Mortality Weekly Report articles are available online from the CDC



MMWR Web site at <http://www.cdc.gov/mmwr/>. Codes of Federal Regulations are available online from the Electronic Code of Federal Regulations Web site at <http://www.ecfr.gov/>.

**AR 200–1**

Environmental Protection and Enhancement

**AR 420–1**

Army Facilities Management

**DOD Policy Memorandum**

Deputy Secretary of Defense, 31 October 2008, subject: Access for People with Disabilities  
<http://www.access-board.gov/guidelines-and-standards/buildings-and-sites/14-architectural-barriers-act/263-dod-memorandum>

**TB MED 576**

Sanitary Control and Surveillance of Water Supplies at Fixed Installations

**ANSI/APSP-7-2006**

American National Standard for Suction Entrapment Avoidance in Swimming Pools, Wading Pools, Spas, Hot Tubs, and Catch Basins

**ANSI/APSP-11-2009**

Standard for Water Quality in Public Pools and Spas  
<http://www.apsp.org>

**ANSI/International Accreditation Forum (IAF)-9-2005**

American National Standard for Aquatic Recreation Facilities

**American Red Cross**

Swimming and Water Safety

**American Red Cross**

Lifeguard Management

**American Red Cross**

Lifeguarding

**American Red Cross**

Safety Training for Swim Coaches

**CDC**

Unintentional Drowning: Get the Facts (Fact Sheet).

<http://www.cdc.gov/HomeandRecreationalSafety/Water-Safety/waterinjuries-factsheet.htm>

**CDC**

Department of Health and Human Services (DHHS) National Institute for Occupational Safety and Health (NIOSH) Publication No. 76–170, Criteria for a Recommended Standard: Occupational Exposure to Chlorine  
<http://www.cdc.gov/niosh/docs/1970/76-170.html>

**CDC MMWR**

Recreational Water-Associated Disease Outbreaks—United States, 2009–2010, vol 63(01); 6–10.

**CDC MMWR**

Surveillance for Waterborne Disease Outbreaks and Other Health Events Associated with Recreational Water—United States, 2007–2008, vol 60(ss12); 1–32.

**CDC MMWR**

Surveillance for Waterborne Disease and Outbreaks Associated with Recreational Water Use and Other Aquatic Facility-Associated Health Events—United States, 2005–2006, vol 57(SS09); 1–29.

**EPA 440/5-84-002**

Ambient Water Quality Criteria for Bacteria—1986  
[http://water.epa.gov/scitech/swguidance/standards/upload/2001\\_10\\_12\\_criteria\\_ambientwqc\\_bacteria1986.pdf](http://water.epa.gov/scitech/swguidance/standards/upload/2001_10_12_criteria_ambientwqc_bacteria1986.pdf)

**EPA 550-F-01-003**

Safe Storage and Handling of Swimming Pool Chemicals

**EPA 821-R-02-022**

Method 1600: Enterococci in Water by Membrane Filtration Using Membrane-Enterococcus Indoxyl- $\beta$ -D-Glucoside Agar (mEI) <http://www.epa.gov/microbes/online.html>

**EPA-823-B-02-003**

Implementation Guidance for Ambient Water Quality Criteria for Bacteria  
[http://water.epa.gov/learn/training/tribaltraining/resources\\_wqs.cfm](http://water.epa.gov/learn/training/tribaltraining/resources_wqs.cfm)

**Federation Internationale de Natation (FINA)**

FINA Handbook 2009–2013  
<http://www.fina.org/shop>

**Illuminating Engineering Society**

The Lighting Handbook  
<http://www.ies.org/handbook/>

**National Collegiate Athletic Association**

NCAA<sup>®</sup> Men's and Women's Swimming and Diving Rules (NCAA<sup>®</sup> is a registered trademark of the National Collegiate Athletic Association.)  
<http://www.ncaapublications.com/p-4076-mens-and-womens-swimming-and-diving-rules.aspx>

**UFC 3-410-01**

Heating, Ventilating, and Air Conditioning Systems  
[http://www.wbdg.org/ccb/DOD/UFC/ufc\\_3\\_410\\_01.pdf](http://www.wbdg.org/ccb/DOD/UFC/ufc_3_410_01.pdf)

**UFC 3-520-01, with Change 2**

Interior Electrical Systems  
[http://www.wbdg.org/ccb/DOD/UFC/ufc\\_3\\_520\\_01.pdf](http://www.wbdg.org/ccb/DOD/UFC/ufc_3_520_01.pdf)

**U.S. Consumer Product Safety Commission (USCPSC)**

Virginia Graeme Baker Pool and Spa Safety Act—Staff Interpretation of Section 1404: “Federal Swimming Pool and Spa Drain Cover Standard”  
[http://www.wvdhhr.org/phs/pools/virginia%20graeme%20baker%20act/cpsc\\_staff\\_interpretation\\_s\\_tradefinal.pdf](http://www.wvdhhr.org/phs/pools/virginia%20graeme%20baker%20act/cpsc_staff_interpretation_s_tradefinal.pdf)

**USCPSC**

Pool or Spa Submersion: Estimated Injuries and Reported Fatalities, 2013 Report  
<http://www.cpsc.gov/en/Media/Documents/Research--Statistics/Injury-Statistics/Sports/Pool-Drowning/2013-Pool-or-Spa-Submersion-Report-Estimated-Injuries-and-Reported-Fatalities/>

**USCPSC**

2008-2012 Reported Circulation/Suction Entrapments Associated with Pools, Spas, and Whirlpool Bathtubs, 2013 Report  
<http://www.cpsc.gov//Global/Research-and-Statistics/Injury-Statistics/Sports-and-Recreation/Pools/2013PoolSpaEntrapments.pdf>

**World Health Organization (WHO)**

Guidelines for Safe Recreational Water Environments, Volume 2: Swimming Pools and Similar Environments  
[http://www.who.int/water\\_sanitation\\_health/bathing/srwe2full.pdf](http://www.who.int/water_sanitation_health/bathing/srwe2full.pdf)

**16 CFR 1207**

Safety Standard for Swimming Pool Slides

**29 CFR 1910.1200**

Hazard Communication

**36 CFR 1190**

Minimum Guidelines and Requirements for Accessible Design

<http://www.gpo.gov/>

**36 CFR 1191**

Americans with Disabilities Act (ADA) Accessibility Guidelines for Buildings and Facilities;  
Architectural Barriers Act (ABA) Accessibility Guidelines

**42 USC 4151 et seq.**

Architectural Barriers Act of 1968, as amended

<http://www.access-board.gov/about/laws/aba.htm>

**Section III**

**Prescribed Forms**

**DA Form 7267-R**

Checklist for Routine Inspection of Swimming Pools (Prescribed in para 4–17a.)

[http://www.apd.army.mil/pub/eforms/pdf/a7267\\_r.pdf](http://www.apd.army.mil/pub/eforms/pdf/a7267_r.pdf)

**Section IV**

**Referenced Forms**

**DA Form 3164-R**

Swimming Pool Operating Log

[http://armypubs.army.mil/eforms/pdf/A3164\\_R.pdf](http://armypubs.army.mil/eforms/pdf/A3164_R.pdf)

**Section V**

**Selected Bibliography**

Alhajj, M., N.G. Nelson, and L.B. McKenzie. 2009. Hot Tub, Whirlpool, and Spa-Related Injuries in the U.S., 1990–2007. *Am J Prev Med.* 37(6):531–536.

[http://www.ajpmonline.org/article/S0749-3797\(09\)00603-5/abstract](http://www.ajpmonline.org/article/S0749-3797(09)00603-5/abstract)

## APPENDIX B

### ROLES AND FUNCTIONS FOR ADDITIONAL INSTALLATION PERSONNEL

---

#### **B–1. Roles and functions**

The following roles and responsibilities apply to various installation staff for the operation and maintenance of recreational water facilities:

*a.* The garrison commander, on installations, and the Armed Forces Recreation Center (AFRC) general manager are responsible for ensuring that recreational water facilities are maintained in sanitary condition. The garrison commander and AFRC general manager will—

- (1) Provide overall supervision of swimming and bathing facilities.
- (2) Enforce safety, health, and sanitation regulations.
- (3) Forward requests for exception from any of the provisions contained in this bulletin through the major Army command to TSG, HQDA (DASG-PPM-NR), Falls Church, VA 22042-5140.

- (4) Ensure that deficiencies found during pre-season or pre-opening inspections are corrected before the facility is opened to the public.

- (5) Ensure risk management, as specified in ATP 5-19, is applied during the planning, construction, operation, and maintenance of recreational water facilities.

*b.* The medical commander or designated representative (from preventive medicine/public health, for example) will—

- (1) Review all concept designs and final plans for the construction of recreational water facilities with regard to sanitary control and safety prior to final acceptance of the plans.

- (2) Investigate suspected illness or injury due to recreational water facilities, and implement remedial measures as appropriate.

- (3) Approve the use of all natural bathing areas under installation control.

*c.* Preventive medicine/public health personnel will—

- (1) Provide medical oversight of the operation and use of recreational water facilities.

- (2) Provide inspections and sanitary surveys as required.

- (3) Maintain a laboratory capability to provide chemical and bacteriological monitoring at recreational water facilities.

- (4) Provide guidance to pool operators and management as necessary.

- (5) Ensure safe and healthful recreational water facilities by—

- (a)* Maintaining information regarding engineering and operational features.

- (b)* Determining that operators and lifeguards are properly trained in the sanitary operation of the facility.

- (c)* Performing pre-opening inspections.

- (d)* Conducting bacteriological and chemical surveillance of pool water.

- (e)* Providing technical reviews prior to renovations or new construction.

- (f)* Performing routine inspections or surveys.

(6) Ensure that water facility oversight activities are conducted only by personnel who have been trained or certified as pool operators or inspectors.

(7) Investigate all complaints of illness potentially related to a recreational water facility.

*d.* The DPW is responsible for the maintenance, repair, and alterations of installed swimming pools and natural bathing area equipment under the control of the installation; DPW personnel will—

(1) Operate and maintain the swimming pool(s) and spa(s) according to TM 5–662 and this bulletin.

(2) Ensure that at least one pool operator maintains a valid CPO/AFO certification.

(3) Ensure proper operation of the recirculation system and adjustment of chemical feed rates (such as pH adjustment and chlorine addition).

(4) Provide emergency engineering assistance to correct health-related deficiencies as they develop; for example, quick responsive action to adjust chlorine or other chemicals after lifeguards have identified inadequate chemical levels.

(5) Maintain appropriate water test kits for each recreational water facility.

(6) Ensure the availability of safety data sheets (SDS) for all hazardous materials used in the pool.

(7) Participate in pre-opening/annual inspections of pools/spas.

(8) Maintain facility equipment.

(9) Perform breakpoint chlorination as necessary.

(10) Notify the appropriate wastewater treatment plant before draining a facility.

(11) Monitor and maintain proper flow rates.

(12) Ensure all facilities are designed according to military and local regulations and that construction documents are approved by a local, or higher, jurisdictional health agency.

(13) Apply the risk management process, as specified in ATP 5-19, during the prioritization and execution of maintenance and repair tasks associated with recreational water facilities.

*e.* Installation safety office personnel will—

(1) Conduct a yearly Standard Safety and Occupational Health Inspection, to include evaluations of the chlorine equipment and attachments, personal protective equipment, respiratory protection program, and electrical and grounding hookups.

(2) Ensure the proper maintenance and placement of personal protective equipment.

(3) Investigate any reported injuries.

(4) Provide oversight and input for recreational water facilities as requested or deemed necessary.

*f.* The DFMWR is responsible for the control of swimmers and for pool cleaning (or janitorial services under the installation's control); DFMWR personnel will—

(1) Ensure that at least one person within the pool management staff maintains a valid pool operator's certificate from a nationally recognized program (CPO or AFO certification).

(2) Ensure the lifeguard staff is adequately trained.

(3) Provide proper lifesaving equipment for all facilities.

(4) Maintain the appropriate test kit onsite for each recreational water facility.

- (5) In coordination with preventive medicine/public health personnel, train lifeguards in the use of chemical water quality test kits.
  - (6) Maintain the facilities, as required, and keep the facilities clean.
  - (7) Ensure proper monitoring is occurring and facility monitoring records are maintained for at least two years following the end of the current season.
  - (8) Ensure a safe recreational water facility.
  - (9) Initiate maintenance of the facility when necessary.
  - (10) Apply risk management, as specified in ATP 5-19, during the operation and maintenance of recreational water facilities.
- g.* Lifeguards will—
- (1) Ensure the required chemical and physical water quality measurements are recorded as specified.
  - (2) Enforce safety, including bather load.
  - (3) Check rescue equipment daily, using the opening checklist to ensure the equipment's availability and serviceability.
  - (4) Record maintenance activity.
  - (5) Ensure drain covers are in place and unbroken.
  - (6) Be properly certified, and complete all required lifeguard training.
  - (7) Alert the pool supervisor and/or DPW when pool parameters require adjustment.
  - (8) Enforce swimmer rules.

## APPENDIX C

## SUGGESTED RULES FOR RECREATIONAL WATER FACILITIES

**C-1. Applicability**

These rules should not necessarily be considered all-inclusive. Local conditions may dictate additional or fewer regulations. Management staff and lifeguards are authorized to correct unsafe or inappropriate behavior; compliance will be enforced.

**C-2. Suggested rules for pools**

- a. Swim at your own risk.
- b. Never use the pool alone.
- c. Persons under the influence of alcohol or drugs are prohibited from using the pool.
- d. Hyperventilation and underwater breath-holding are not permitted.
- e. Parents are responsible for their children, to include teaching them the pool rules and instructing them to obey the lifeguards.
- f. Running, diving (other than in the prescribed diving area(s)), rough play, excessive noise, and/or profane language are not permitted.
- g. While in the water, patrons are not permitted to consume food, drink, or chewing gum.
- h. Spitting, spouting of water, and/or blowing one's nose is not permitted in the pool.
- i. Dispose of trash properly.
- j. Glass containers are NOT permitted.
- k. All pool patrons must shower before entering the pool.
- l. Persons who have been ill with diarrhea or vomiting in the last 2 weeks are not permitted in the pool.
- m. Persons with skin infections, open wounds, communicable diseases, and eye, nose, or throat infections or discharges are not permitted in the pool.
- n. Children must be completely potty-trained to enter the large pool. Children wearing diapers, including "swimmies," are not allowed in the large pool.
- o. Children taller than 42 inches are not allowed in the wading pool.
- p. Any injury that occurs on the premises must be reported to the pool manager immediately.
- q. Bathing load: \_\_\_ persons.
- r. Pool hours: \_\_\_ a.m. to \_\_\_ p.m.
- s. In an emergency, call 911.
- t. The emergency phone is located at (*insert facility information*).
- u. A first-aid kit is located at (*insert facility information*).

**C-3. Additional suggested rules for spas**

- a. Do not use the spa alone.



- b. Children under 5 years old are not permitted in the spa.
- c. Children 5–12 years old must be accompanied by an adult.
- d. No soap or bubble bath is allowed.
- e. Do not use the spa at water temperatures above 104 °F.
- f. Limit spa use to 15 minutes. Long exposure may result in nausea, dehydration, dizziness, fainting, or death.
- g. The maximum number of people allowed in the spa is (*insert number*).
- h. People with heart disease, diabetes, high blood pressure; and women who are or may be pregnant are advised to consult a physician before using the spa.
- i. Do not use the spa pool while under the influence of alcohol, tranquilizers, or other drugs which may cause drowsiness, alter blood pressure, or put the patron at risk.
- j. Anyone with symptoms of a disease or illness is prohibited from entering the spa.
- k. Do not use the spa with any open wounds (to include vaccinations or bandaged wounds).
- l. Failure to comply with these regulations constitutes grounds for management action or exclusion from the premises, as necessary.

**C–4. “Dos and don’ts” for diving into swimming pools equipped with manufactured diving equipment**

- a. Do know the shape of the pool bottom and the water depth before you dive or slide.
- b. Do plan your path to avoid submerged obstacles, surface objects, or other swimmers.
- c. Do hold your head and arms up, and steer up with your hands.
- d. Do practice carefully before you dive or slide.
- e. Do test the diving board for its spring before using.
- f. Do remember that when you dive down, you must steer up.
- g. Do dive straight ahead from—not off the side of—the diving board.
- h. Don’t drink and dive.
- i. Don’t dive or slide headfirst in the shallow part of the pool.
- j. Don’t dive across the narrow part of the pool.
- k. Don’t run and dive.
- l. Don’t dive from any place that is not specifically designed for diving.
- m. Don’t engage in horseplay on diving or sliding equipment.
- n. Don’t use diving equipment as a trampoline.
- o. Don’t do a back dive.
- p. Don’t try any fancy dives; keep the dives simple.
- q. Don’t dive or slide headfirst at or through objects such as inner tubes.
- r. Don’t install diving or sliding equipment at a pool that was not designed for it.
- s. Don’t swim or dive alone.
- t. Don’t dive into unfamiliar bodies of water.

**C–5. Rules for general use of swimming pool slides**

- a. Entering the pool headfirst from a slide is prohibited.
- b. Horseplay is prohibited.

- c.* Non-swimmers are prohibited from entering deep water from a slide.
- d.* Standing on the top of a slide or outside the guardrails is prohibited.
- e.* Jumping from a slide is prohibited.
- f.* Diving from a slide is prohibited.
- g.* Sliding into areas where submerged obstacles, surface objects, or other swimmers are located is prohibited.

## APPENDIX D

WATER QUALITY REQUIREMENTS FOR AQUATIC VENUES<sup>1</sup>

Table D–1. Water chemistry requirements for aquatic venues

Parameter	Minimum	Ideal	Maximum	Minimum Monitoring Frequency
Free chlorine—pools, splash pads, aquatic play features (mg/L)	1.0 2.0 <sup>2</sup>	2.0	5.0	Every 2 hours (hrs)
Free chlorine—spas/therapy pools (mg/L)	3.0	3.0–5.0	10.0	Every 2 hrs
Combined chlorine (mg/L)	0.0	0.0	0.4	Weekly
Bromine (mg/L)	3.0 (pools) 6.0 (spas)	3.0 (pools) 6.0 (spas)	4.0 (pools) 6.0 (spas)	Every 2 hrs
ORP (millivolts)	650	750–900	N/A	Every 2 hrs
pH	7.2	7.4–7.6	7.8	Every 2 hrs
Total alkalinity (mg/L)	60	80–120	180	Weekly
Calcium hardness—pools (mg/L)	150	200–400	400	Monthly
Calcium hardness—spas (mg/L)	100	150–250	800	Monthly
Total dissolved solids (mg/L)	0	N/A	1,500 above fill water TDS level	Quarterly
Cyanuric acid (mg/L)	0	30	50	Monthly <sup>2</sup> Biweekly <sup>3</sup>
Temperature (°F)—pools	70	78–82	104	Twice a day
Temperature (°F)—spas	70	Personal preference	104	Every 2 hrs

<sup>1</sup>Aquatic venues include pools, spas, and aquatic play features.

<sup>2</sup>Pools adding cyanuric acid

<sup>3</sup>Pools using stabilized chlorine as the primary disinfectant

**Table D–2. Bacteriological requirements for aquatic venues**

Indicator Organism	Single Sample Limit (CFU/mL)	Monitoring Frequency
HPC <sup>a</sup>	≤ 200	At least weekly
Total coliforms (defined substrate <sup>b</sup> )	0	As necessary
Total coliforms (MF)	< 2 CFU/100 mL	As necessary
Total coliforms (MTF)	0	As necessary
Staphylococci	≤ 50 CFU/100 mL	As necessary
<i>P. aeruginosa</i>	< 1 CFU/100 mL	As necessary

Notes:

<sup>a</sup> Required monitoring for all pools and spas<sup>b</sup> Use of defined substrate without means to quantify**Table D–3. Bacteriological requirements for natural bathing areas**

Indicator	BAV (CFU/100 mL)	Monitoring Frequency
Enterococci (fresh and marine waters)	70	At least weekly
<i>E. coli</i> (fresh water)	235	At least weekly

## APPENDIX E

### SAFE STORAGE AND HANDLING OF CHEMICALS

---

#### **E-1. Manufacturer recommendations for storage**

*a.* Chemicals must be stored in a safe manner according to manufacturer recommendations. Pool chemicals should be stored at temperatures below 95 °F/35 °C and in compliance with local or state building and fire codes.

*b.* Chemicals should be stored in the manufacturer's original, labeled containers. Containers will be labeled properly and covered with an appropriate lid at all times. Secondary containment will be provided to contain any spills.

#### **E-2. Storage for incompatible chemicals**

*a.* Chemicals that are incompatible will not be stored in close proximity to each other, and cleaning chemicals will be stored in a separate location. Only identical chemicals will be stored above or below each other (that is, do not stack incompatible chemicals together). This is particularly important for liquid chemicals, which can leak and then mix with other pool chemicals or substances stored below.

*b.* Containers of any pool chemical will not be stored directly on the floor.

#### **E-3. Handling open containers**

*a.* Opened containers will be covered with waterproof material. The chemical storage area should be checked regularly for any evidence of water entry, and any identified problems should be corrected immediately.

*b.* Potential routes of water entry include roofs, ceilings, windows (open or broken windows, in particular), doors, walls, wall/floor joints, water pipes/hoses, sprinkler systems, and drains (faulty or clogged drains, in particular).

#### **E-4. Protection from heat sources**

*a.* Pool chemicals should be protected from heat sources and flames.

*b.* Possible sources of ignition (such as welding equipment), especially gasoline-, diesel-, or gas-powered equipment (such as lawn mowers, motors, grills, or portable stoves) should never be stored in the chemical storage area.

*c.* Smoking is not permitted in the chemical storage area.

#### **E-5. Good housekeeping**

*a.* Good housekeeping should be a priority in the chemical storage area.

*b.* Rags, trash, debris, etc., should not be allowed to collect in the area.

**E-6. Limit storage of chemical supply**

- a. Stored supplies of chemicals should be limited by having frequent, regular deliveries.
- b. The inventory should be rotated on a first-in, first-out basis.

**E-7. Bulk chlorine storage**

- a. Bulk chlorine storage (powder, granular, and liquid forms), compressed chlorine gas or CO<sub>2</sub> cylinders, and any other water treatment operations and chemicals should be isolated from other swimming pool areas.
- b. The area(s) should be maintained in a dry condition. Storage of all chemicals must be according to the applicable SDS.
- c. An SDS should be kept on file for all chemicals that are stored onsite.

**E-8. Security of chemical cylinders**

- a. All chlorine and CO<sub>2</sub> cylinders should be secured to prevent rolling or falling.
- b. Empty cylinders should be segregated from full cylinders, and cylinders should be tagged appropriately.
- c. Cylinders should not be stored near ventilation system motors, heat sources, or areas of elevated temperature.
- d. Cylinders should be stored above ground in a well-ventilated area separated from the pool and other occupied areas by a gas-tight partition.

**E-9. Mechanical ventilation**

- a. Mechanical ventilation should be provided in facilities where chlorine cylinders are stored.
- b. Mechanical exhaust ventilation will be provided at the rate of one air change every minute (or faster) and take suction near the floor as far from the door and the fresh air intake as is practical. The controls must be located outside the room. The mechanical ventilation must be wired so it can be turned on manually or will engage automatically when the lights are turned on.
- c. Exhausted air must be ducted to the exterior of the building through a continuous pipe that is at least 1½ inches in diameter with the point of discharge located so as not to contaminate the air inlets to any rooms or structures.

**E-10. Storage facilities**

- a. Storage facilities must be lockable.
- b. All doors should be hinged to open outward, and at least one door must have a viewport to permit operators to look into the room before entering it.
- c. Written operating instructions for the handling and use of chlorine will be posted near the chlorination facility.

**E-11. Warning sign**

The following warning sign should be affixed in a readily visible location at or near the entrance(s) to the chlorination room:

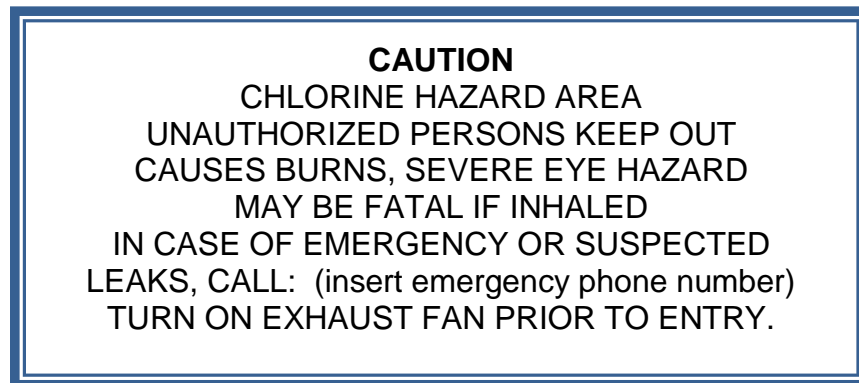

**Figure E-1. Warning sign near chlorination room**

**E-12. Automatic alarms**

- a. Automatic chlorine alarms must be installed at all chlorine gas storage facilities.
- b. A documented inspection maintenance and calibration program for chlorine detectors and alarms must be in effect.

**E-13. Protective equipment**

- a. Personnel entering the area for routine inspection will wear chemical goggles.
- b. Personnel must wear impervious (neoprene or Teflon<sup>®</sup>) gloves, chemical goggles, and a full faceshield when changing cylinders or adjusting the system. (Teflon<sup>®</sup> is registered trademark of E.I. du Pont de Nemours and Company, Wilmington, Delaware.)

**E-14. Spill or chlorine leak**

- a. Swimming pool operators or lifeguards must not enter chlorinated rooms or chlorine storage areas if a release of chlorine or a system malfunction is suspected.
- b. If a spill or chlorine leak occurs, the installation emergency response team must be contacted immediately.
- c. Only trained personnel wearing appropriate chemical protective clothing should enter the area.
- d. Personnel who enter the chlorinator room to inspect the cylinder visually, to adjust the cylinder and system, and/or to change the cylinder will carry a National Institute for Occupational Safety and Health (NIOSH)-approved 5- or 10-minute escape-only respirator.
- e. All personnel who are required to wear respiratory protection, including escape-only respirators, must be medically fit-tested (if appropriate) and cleared; trained; and enrolled in the installation respiratory protection program, as defined in AR 11-34 and 29 CFR 1910.134.

*f.* The requirement to carry an escape-only respirator may be waived by the medical commander, based on either individual sampling results or the use of a chlorine alarm.

**E-15. Leak repairs**

Only personnel properly equipped with and trained in the use of self-contained breathing apparatus (SCBA) will repair leaks.

- a.* Two sets of SCBA equipment should be maintained—
  - (1) At a central location so they may be used throughout the installation when the need arises.
  - (2) In accordance with the installation respiratory protection program (see TB MED 502).
- b.* The SCBA equipment should be stored outside of chlorination rooms in a neutral area that is readily accessible.
- c.* In addition to the full-face SCBA, personnel will wear protective clothing, neoprene gloves, a chemical-protection apron, and boots.

**E-16. Eye safety**

- a.* An eye lavage and a deluge shower shall be provided at the chlorination facility for use in case of emergency.
- b.* Passageways to the eye lavage and deluge shower must be kept clear and unobstructed.



APPENDIX F

**WATER CONTAMINATION RESPONSE LOG**  
*(Adopted from Draft CDC Model Aquatic Health Code)*

Water Contamination Response Log

Person Conducting Contamination Response						
Supervisor on Duty						
Date (mm/dd/yyyy) of Incident Response						
Time of Incident Response						
Water Feature or Area Contaminated						
Number of People in Water						
Type/Form of Contamination in Water: Fecal Accident (Formed Stool or Diarrhea), Vomit, Blood						
Time that Water Feature was Closed						
Stabilizer Used in Water Feature (Yes/No)						
	Water Quality Measurements					
	Level at Closure	1	2	3	4	Level Prior to Reopening
Free Residual Chlorine (1-4 are measurements spread evenly thru the closure time)						
pH (1-4 are measurements spread evenly thru the closure time)						
Date (mm/dd/yyyy) that Water Feature was Reopened						
Time that Water Feature was Reopened						
Total Contact Time (Time from when disinfectant reached desired level to when disinfectant levels were reduced prior to opening)						
Remediation Procedure(s) Used and Comments/Notes						

Figure F-1. Sample water contamination response log

## APPENDIX G

## USE OF THE LANGEЛИER INDEX TO BALANCE POOL WATER

**G–1. General**

*a.* In pool waters, calcium bicarbonate is very soluble. When it breaks down, it forms the insoluble calcium carbonate, the chief scale former. Scale generally appears as white or lightly-colored rough blotches on pool walls. It also adheres to other objects in the pool. Calcium carbonate scale in the piping and filter system can restrict water flow and cause calcification of the filter bed, thus reducing filtration efficiency and shortening filter runs.

*b.* Scale deposits are usually caused by the presence of excess calcium and magnesium in pool water. These minerals become insoluble and can form scale. The factors which influence the formation of scale are—

- (1) Calcium hardness.
- (2) Total alkalinity.
- (3) The pH level.
- (4) Water temperature.
- (5) Total dissolved solids.

**G–2. Preventing scale-forming tendencies**

*a.* The five factors above can be given numerical values and applied to a formula known as the Langelier Index, or Saturation Index. The formula indicates whether water has scale-forming tendencies and how the condition can be corrected. In the Langelier table (table G–1), numerical values are given for three of the five factors. An average factor for total solids is included in the formula. By using figures from the table and the following simplified version of the Langelier formula, the proper alkalinity balance of a pool's water—and hence its ability to resist scale-forming or corrosive tendencies—is obtained.

**Table G–1. Numerical values for Langelier formula**

Temp (°C)	TF	Ca Hardness (mg/L CaCO <sub>3</sub> )	CF	Total Alkalinity (mg/L CaCO <sub>3</sub> )	AF
0	0	5	0.3	5	0.7
3	0.1	25	1.0	25	1.4
8	0.2	50	1.3	50	1.7
12	0.3	75	1.5	75	1.9
16	0.4	100	1.6	100	2.0
19	0.5	150	1.8	150	2.2
24	0.6	200	1.9	200	2.3
29	0.7	300	2.1	300	2.5

**Table G–1. Numerical values for Langelier formula (continued)**

Temp (°C)	TF <sup>1</sup>	Ca <sup>2</sup> Hardness (mg/L CaCO <sub>3</sub> ) <sup>3</sup>	CF <sup>4</sup>	Total Alkalinity (mg/L CaCO <sub>3</sub> )	AF <sup>5</sup>
34	0.8	400	2.2	400	2.6
40	0.8	800	2.5	800	2.9
53	1.0	1,000	2.6	1,000	3.0

<sup>1</sup>TF – temperature factor<sup>2</sup>Ca – calcium<sup>3</sup>mg/L CaCO<sub>3</sub> – milligrams of calcium carbonate per liter<sup>4</sup>CF – calcium [hardness] factor<sup>5</sup>AF – [total] alkalinity factor

$$\text{Saturation Index} = \text{pH} + \text{TF} + \text{CF} + \text{AF} - 12.1$$

Where:

pH = actual reading

TF = temperature factor

CF = calcium hardness factor

AF = total alkalinity factor

b. For example—

(1) If the Saturation Index is 0, the water is chemically in balance.

(2) If the Saturation Index is a negative (–) value, corrosive tendencies are indicated.

(3) If the Saturation Index is a positive (+) value, scale-forming tendencies are indicated.

c. A pool's Saturation Index is considered satisfactory if the value is between +0.5 and –0.5.

**G–3. Examples**

The following examples show how to use the Saturation Index to determine the appropriate adjustment of pool water.

a. The following example illustrates a pool with soft water having low temperature, low alkalinity, and low hardness.

(1) Saturation Index.

$$\begin{aligned}\text{Saturation Index} &= 7.2 + 0.3 + 0.3 + 0.7 - 12.1 \\ &= -3.6\end{aligned}$$

Where:

pH = 7.2

Calcium hardness = 5 mg/L

Total alkalinity = 5 mg/L

TF = 0.3

CF = 0.3

AF = 0.7

(2) Corrective action. This high negative Saturation Index shows an extremely corrosive condition.

(a) To correct it, add sodium bicarbonate ( $\text{NaHCO}_3$ ), which has a mild effect on pH, to increase the alkalinity to about 100 mg/L. (Note: 1.5 pounds  $\text{NaHCO}_3$  per 10,000 gallons of water will raise the alkalinity by 10 mg/L.)

(b) To correct the problem of low water hardness, add a chemical such as calcium chloride ( $\text{CaCl}_2$ ) to increase the hardness level to a minimum of about 100 mg/L. (Note: One pound of  $\text{CaCl}_2$  per 10,000 gallons of water will raise the calcium hardness by approximately 11 mg/L.)

(c) The water temperature can also be increased to a more comfortable level of about 70 °F (21 °C).

(d) Finally, if required, adjust the pH to the desired 7.2–7.6 range. In its adjusted condition, the pool water should now be in balance, as shown in the Saturation Index below.

$$\begin{aligned}\text{Saturation Index} &= 7.6 + 0.5 + 1.6 + 2.0 - 12.1 \\ &= -0.4\end{aligned}$$

Where:

pH = 7.6

Temperature = 70 °F

Calcium hardness = 100 mg/L

Total alkalinity = 100 mg/L

TF = 0.5

CF = 1.6

AF = 2.0

b. The following example illustrates a pool with both hard and highly alkaline water.

(1) Saturation Index:

$$\begin{aligned}\text{Saturation Index} &= 8.5 + 0.7 + 2.5 + 2.6 - 12.1 \\ &= 2.2\end{aligned}$$

Where:

pH = 8.5

Temperature = 84 °F (29 °C)

Calcium hardness = 800 mg/L

Total alkalinity = 400 mg/L

TF = 0.7

CF = 2.5

AF = 2.6

(2) Corrective action. This positive Saturation Index shows an extreme tendency to form scale.

(a) The first factors to consider when correcting this condition are the pH and total alkalinity since they can be adjusted most readily.

(b) To correct this condition, add muriatic acid, hydrochloric acid (HCl), or sodium bisulfate (NaHSO<sub>4</sub>) daily to lower the pH and total alkalinity to approximately 75 mg/L.

(c) Add 1.5 pints of muriatic acid per 10,000 gallons of water to lower the alkalinity 10 mg/L. The pool water is now in balance, as shown by the near-zero Saturation Index below.

$$\begin{aligned} \text{Saturation Index} &= 7.4 + 0.7 + 2.5 + 1.9 - 12.1 \\ &= 0.4 \end{aligned}$$

Where:

pH = 7.4  
 temperature = 84 °F (29 °C)  
 calcium hardness = 800 mg/L  
 total alkalinity = 75 mg/L  
 TF = 0.7  
 CF = 2.5  
 AF = 1.9

c. The next example illustrates a pool with balanced water.

(1) This example shows a balanced condition and also demonstrates that with a pH of 7.6, a total alkalinity of 50 mg/L, and a temperature of 76 °F (24 °C), the Saturation Index is at a satisfactory value despite a calcium hardness range of 150 mg/L (CF = 1.8) to 1,000 mg/L (CF = 2.6):

$$\begin{aligned} \text{Saturation Index} &= 7.6 + 0.6 + 1.8 + 1.7 - 12.1 \\ &= -0.4 \end{aligned}$$

$$\begin{aligned} \text{Saturation Index} &= 7.6 + 0.6 + 2.6 + 1.7 - 12.1 \\ &= 0.4 \end{aligned}$$

Where:

pH = 7.6  
 temperature = 76 °F (24 °C)  
 calcium hardness = 400 mg/L  
 total alkalinity = 50 mg/L  
 TF = 0.6  
 CF = 2.2  
 AF = 1.7

(2) Maintaining the total alkalinity at 50–100 mg/L and the pH range from 7.2–7.6 has four benefits:

- (a) Residual available chlorine controls the bacteria and algae more efficiently.
- (b) Scale formation is minimized.
- (c) Scaling of heater coils is reduced to a minimum.
- (d) Any problem resulting from a chemical imbalance in the pool water is eliminated.

**G–4. Maintaining balanced pool water**

a. In the Saturation Index formula, a change in pH of a given value will change the index by a like amount. The most direct method of lowering pH is to add a common acid material such as muriatic acid, HCl. This treatment not only lowers pH, but also reduces total alkalinity. Do not permit the pH of the water to drop below 7.2.

b. Most chemicals used during the normal treatment of pool water will affect scale formation to some degree. Chlorine gas, muriatic acid, and other acid materials tend to reduce scale formation, while hypochlorites, soda ash, and caustic soda tend to facilitate its formation.

c. By keeping track of the chemicals added to a pool and by controlling pH (by far the simplest factors to measure and control), the pool operator can learn to keep the water in proper balance.

## GLOSSARY

### Section I Acronyms and Abbreviations

**ABA**  
Architectural Barriers Act

**ADA**  
Americans with Disabilities Act

**AED**  
automated external defibrillator

**AF**  
[total] alkalinity factor

**AFO**  
aquatic facility operator

**AGI**  
acute gastrointestinal illness

**ANSI**  
American National Standards Institute

**APD**  
Army Publishing Directorate

**APF**  
aquatic play feature

**APHA**  
American Public Health Association

**APSP**  
Association of Pool and Spa Professionals

**AR**  
Army Regulation

**ARI**

acute respiratory illness

**ASHRAE**

American Society of Heating, Refrigeration, and Air Conditioning

**ASME**

American Society of Mechanical Engineers

**ASSE**

American Society of Sanitary Engineers

**ASTM**

American Society for Testing and Materials

**AWWA**

American Water Works Association

**C**

Celsius

**CDC**

Centers for Disease Control and Prevention

**CF**

calcium hardness factor

**cfm/sq ft**

cubic feet per minute per square foot

**CFR**

Code of Federal Regulations

**CFU**

colony-forming unit(s)

**CO<sub>2</sub>**

carbon dioxide

**CPO**

Certified Pool Operator



**CPR**

cardio-pulmonary resuscitation

**CT**

chlorine concentration

**DA**

Department of the Army

**DA PAM**

Department of the Army Pamphlet

**DBP**

disinfection byproduct(s)

**DHHS**

Department of Health and Human Services

**DOD**

Department of Defense

**DPD**

diethyl-P-phenylene diamine

**DFMWR**

directorate of family, morale, welfare and recreation

**DPW**

directorate of public works

**F**

Fahrenheit

**FAC**

free available chlorine

**FINA**

Federation Internationale de Natation

**GFCI**

ground-fault circuit interrupter

**HAA**

haloacetic acid

**HOCl**

hypochlorous acid

**HPC**

heterotrophic plate count

**HQDA**

Headquarters, Department of the Army

**MAHC**

Model Aquatic Health Code

**MEDCEN**

U.S. Army Medical Center

**MEDDAC**

U.S. Army Medical Department Activity

**MF**

membrane filtration

**mg/L**

milligrams per liter

**MMO-MUG**

4-methylumbelliferyl- $\beta$ -D-glucuronide

**MMWR**

Morbidity and Mortality Weekly Report

**MPN**

most probable number

**MTF**

multiple tube fermentation

**NCAA**

National Collegiate Athletic Association

**NEC**

National Electrical Code

**NFPA**

National Fire Protection Association

**NIOSH**

National Institute for Occupational Safety and Health

**NSF**

National Sanitation Foundation

**NSPF**

National Swimming Pool Foundation

**NSPI**

National Spa and Pool Institute

**ONPG**

ortho-nitrophenyl- $\beta$ -D-galactopyranoside

**ORP**

oxidation-reduction potential

**OSHA**

Occupational Safety and Health Administration

**OTSG**

Office of the Surgeon General

**PFD**

Personal flotation device

**POPM**

Proponency Office for Preventive Medicine

**SCBA**

self-contained breathing apparatus

**SDS**

Safety data sheet

**SPF**

Sun Protection Factor

**SVRS**

Safety Vacuum Release System

**TAC**

total available chlorine

**TB MED**

Technical Bulletin, Medical

**TC**

Training Circular

**TF**

temperature factor

**THM**

trihalomethane

**TM**

Technical Manual

**UFC**

Unified Facilities Criteria

**USAPHC**

U.S. Army Public Health Command

**U.S.C.**

United States Code

**USCPSC**

U.S. Consumer Product Safety Commission

**USEPA**

U.S. Environmental Protection Agency

**UV**

ultra-violet

**WBDO**

waterborne disease outbreak

**WEF**

Water Environment Federation

**WHO**

World Health Organization

**YMCA**

Young Men's Christian Association

**Section II**

**Terms**

**pH**

potential of hydrogen (positive hydrogen ion concentration)

**VGB Act**

Virginia Graeme Baker Pool and Spa Safety Act

**Section II**

**Definitions**

**Agitated water**

An aquatic venue with mechanical means (aquatic features) to discharge, spray, or move the water's surface above and/or below the static water line of the aquatic venue. Where there is no static water line, movement shall be considered above the deck plane.

**Algae**

Primitive plants, single or multi-celled, usually aquatic and nonvascular, and capable of elaborating their foodstuffs by photosynthesis.

**Alkalinity**

A measure of the buffering capacity of a solution or its ability to resist a change in pH. Alkalinity represents the sum of the concentrations of bicarbonates, carbonates, and hydroxides expressed as calcium carbonate.

**Aquatic facility**

A physical place consisting of one or more aquatic venues and support infrastructure under a single management structure.

**Aquatic feature**

An individual component within an aquatic venue. Examples include mushrooms, slides, buckets, spray guns/nozzles, and other play features.

**Aquatic play feature**

Water-containing attractions at a recreational water facility that include, but are not limited to, wave pools, water slides, interactive play systems, Leisure Rivers, Action Rivers, and other special-use pools.

**Aquatic venue**

An artificially constructed or modified natural structure where the general public is exposed to water intended for recreational or therapeutic purposes. Such structures do not necessarily contain standing water, so water exposure may occur via contact, ingestion, or aerosolization. Examples include swimming pools, wave pool, rivers, spas (including spa pools and hot tubs), therapeutic pools, and spray pads/interactive water venues. Aquatic venues do not include natural bathing waters.

**Automated controller**

A system of at least one chemical probe, a controller, and an auxiliary or integrated component that senses the level of one or more water parameters and provides a signal to other equipment to maintain the parameters within a user-established range.

**Backflow**

A hydraulic condition caused by a change in water pressure that causes non-potable water or other liquid to enter the potable water system by either backpressure or back-siphonage.

**Backwash**

The process of reversing water flow through a filter in order to remove entrapped particles and thereby clean the media.

**Bacteria**

Single-celled microorganisms which have no chlorophyll and multiply by simple division; they do not contain a true cell nucleus.

**Bather**

A person at an aquatic venue who has contact with water either through spray or partial or total immersion. The term “bather,” as defined, also includes staff members and refers to those users who can be exposed to contaminated water as well as potentially contaminate the water.

**Bather load**

The maximum number of persons allowed in an aquatic venue's water. Bather load is used to determine the number of rinse and cleaning showers. Bather load is not the same as "occupant load," which refers to the maximum aquatic facility load.

**Beach Action Value**

Beach Action Values (BAVs) are conservative, precautionary tools that can serve as the basis for issuing health advisories at beaches.

**Breakpoint chlorination**

The conversion of inorganic chloramine compounds to nitrogen gas. Chlorine added to water that contains ammonia (from urine, sweat, or the environment, for example) reacts with the ammonia to form chloramines. If more chlorine is added, the total residual chlorine continues to rise until the concentration reaches a point that forces the reaction with ammonia to go to rapid completion. In this reaction, the inorganic chloramines are converted to dichloramine, then to nitrogen trichloride, and then to nitrogen gas. Compounds of nitrogen and chlorine are released into the water, and the apparent residual chlorine decreases. The point at which the drop occurs is referred to as the "breakpoint." The amount of free chlorine that must be added to the water to achieve breakpoint chlorination is approximately ten times the amount of combined chlorine in the water. As additional chlorine is added, all inorganic combined chlorine compounds disappear, resulting in a decrease in "chlorine odors" and the potential for eye irritation.

**Catch pool**

A pool or designated section of a pool located at the exit of one or more water slide flumes. The body of water is provided for the purpose of terminating the slide action and providing a means of exit to a deck or walkway area.

**Chloramine**

Any of various compounds containing chlorine and nitrogen.

**Chlorination**

The application of chlorine to water, generally for the purpose of disinfection, but frequently for accomplishing other biological or chemical results.

**Clarification**

The process of removing suspended or colloidal matter from a turbid liquid.

**Clarity**

A term describing the clearness of water; the absence of suspended matter which affects transmission of light.

**Coagulant**

A material that, when added to water, will combine with certain substances ordinarily present and form precipitate comprising floc particles, more or less gelatinous in character, having the capacity to remove colloids from water.

**Coagulation**

- a. The agglomeration of colloidal or finely divided suspended matter by the addition to the liquid of an appropriate chemical coagulant by biological processes or by other means.
- b. The process of adding a coagulant and other necessary reactants.

**Colloids**

Very fine solid particles that will not settle out by their own action. Colloids may be removed by coagulation or by biochemical action.

**Contamination**

A general term signifying the introduction of microorganisms, chemicals, wastes, or sewage into water, thus rendering it unfit for its intended use.

**Contamination Response Plan**

A plan for handling contamination from formed stools, diarrheal stools, vomit, and contaminations involving blood.

**Corrosion**

The gradual deterioration or destruction of a substance or material by chemical action, frequently induced by electrochemical processes, the action proceeding inward from the surface.

**CT value**

A representation of the concentration of the disinfectant (C) multiplied by time in minutes (T) needed for inactivation of a particular contaminant. The concentration and time are inversely proportional; therefore, the higher the concentration of the disinfectant, the shorter the contact time required for inactivation.

**Cyanuric acid (also CYA)**

A chemical that forms a weak bond with free chlorine in outdoor pools, protecting the chlorine from the sun's ultraviolet rays to reduce chlorine loss. Cyanuric acid will reduce the overall effectiveness of chlorine, so it may not be used in indoor pools.

**Deck**

See "pool decks."

**Diaper-aged children**

Children younger than 5 years of age.



**Diatomaceous earth (diatomite)**

Minute, variously shaped, silica skeletons of diatoms that were small, single-cell marine plants that lived years ago. Diatomaceous earth is often used as a filter medium in swimming pool filters.

**Disinfection**

A treatment that kills microorganisms (bacteria, viruses, and parasites, for example). In water treatment, a chemical (commonly chlorine, chloramine, or ozone) or physical process (such as ultraviolet radiation) can be used.

**Disinfection by-product**

An undesirable chemical compound formed by the reaction of a disinfectant (such as chlorine) with a precursor (such as natural organic matter, nitrogenous waste from bathers) in a water system (pool, water supply).

**Drop slides**

Slides of various configurations in which riders are dropped into pool water from a height above the water rather than delivered to water level for entry.

**Emergency Action Plan**

A plan that details the levels of response to specific aquatic emergencies. It should also identify the responder (at each level), each responder's tasks, and the equipment that is necessary for completing the task/response.

**EPA-registered**

All pesticide products regulated and registered under the Federal Insecticide, Fungicide, and Rodenticide Act (FIFRA) by the U.S. Environmental Protection Agency (EPA; <http://www.epa.gov/agriculture/lfra.html>). EPA-registered products will have a registration number on the label (usually stating "EPA Reg No." followed by a series of numbers). This registration number can be verified via the EPA National Pesticide Information Retrieval System (<http://ppis.ceris.purdue.edu/#>). EPA maintains a Selected EPA-registered Disinfectants List at <http://www.epa.gov/oppad001/chemregindex.htm>.

a. Products that do not bear an EPA or equivalent national standard marking recognized by the medical authority may not be used until reviewed and approved by the medical authority.

b. Foreign brands, such as brands that meet EU standards for disinfection, may be used overseas when approved by the medical authority or Command Surgeon. Disinfectants shall contain bactericidal, fungicidal, and virucidal activity.

**Epidemiology**

The study of causes and control of illness or disease in a population.

**Filter**

A device or structure for removing solid or colloidal material, usually of a type that cannot be removed by sedimentation, from water or other liquid.

**Flat water**

An aquatic venue in which the water line is static except for movement made by users.

**Flume**

A high-water-flow water slide with deep riding channels and vertical/lateral curves that accommodate riders either using or not using mats, tubes, rafts, and other water transport vehicles.

**Free Available Chlorine**

The portion of total chlorine that is not combined chlorine and is available as disinfectant in the water. When chlorine is added to water, hypochlorous acid is produced in either the molecular state (HOCl) or the ionized state (hypochlorite ion (OCl<sup>-</sup>) plus hydrogen ion (H<sup>+</sup>)), and a by-product specific to the type of chlorine is produced. The pH of the water determines the amount of hypochlorous acid in each state. HOCl is a very effective bactericide and is the active available chlorine disinfectant in the water. OCl<sup>-</sup> is also a bactericide but acts more slowly than HOCl. Thus, chlorine is a much less effective bactericide at high pH. The sum of HOCl and OCl<sup>-</sup> is referred to as “free chlorine” in pool water. The hypochlorous acid that remains in pool water uncombined with ammonia is called “free chlorine residual.” A free chlorine residual must be maintained for adequate disinfection.

**Foot bath**

Standing water in which patrons or aquatics staff rinse their feet.

**Hard water**

Water containing high concentrations of calcium and magnesium. It is difficult to obtain lather with soap in hard water. Hard water can result in scale in boilers and pipes.

**Heterotrophic bacteria**

Bacteria which require organic carbon as a source of energy for life processes.

**Hypochlorite**

Chemical compounds, including calcium hypochlorite (solid) and sodium hypochlorite (liquid), used as a chlorine carrier in pools and spas.

**Inlet**

A wall or floor fitting where treated water is returned to the pool.

**Isocyanurate**

Compounds of stabilized chlorine containing a form of cyanuric acid.

**Leisure River**

A manufactured stream in which the water is moved by pumps or other means of propulsion to provide a river-like flow that transports bathers over a defined path that may include water aquatic features and play devices.

**Monitoring**

The regular and purposeful observation and checking of systems or facilities and recording of data, including system alerts, excursions from acceptable ranges, and other facility issues. Monitoring includes human and electronic means.

**Movable floor**

A pool floor whose depth varies through the use of controls.

**Natatorium**

A building which contains one or more aquatic venues.

**Occupant load**

The combined total of the bather load and the dry deck, pool deck, and perimeter deck surrounding an aquatic venue. A venue's occupant load is used to determine its required number of toilets, sinks, and diaper-changing stations.

**Oocyst**

The thick-walled, environmentally resistant structure released in the feces of infected animals. Oocysts transfer the infectious stages of sporozoan parasites (such as *Cryptosporidium*) to new hosts.

**Oxidation**

The process of changing the chemical structure of water contaminants by increasing the number of oxygen atoms or reducing the number of electrons of the contaminant. This process allows the contaminant to be more readily removed from the water or to become more soluble in the water. It is the "chemical cleaning" of pool water. Oxidation can be achieved by chlorine, bromine, ozone, and potassium monopersulfate.

**Oxidation-reduction potential**

A measure of a solution's tendency to either gain or lose electrons. A higher (more positive) reduction potential indicates a more oxidative solution.

**Pathogenic**

Disease-producing.

**pH**

A symbol that expresses the negative log of the concentration of hydrogen ions. When water ionizes, it produces hydrogen ions (H<sup>+</sup>) and hydroxide ions (OH<sup>-</sup>). If an excess of hydrogen ions is present, the water is acidic. If an excess of hydroxide ions is present, the water is basic. The numeric value of pH ranges from 0 to 14; the pH of pure water is 7.0. Water is said to be basic, or alkaline, if its pH is higher than 7.0. If its pH is lower than 7.0, the water is acidic. As pH is raised, more ionization occurs, and the effectiveness of chlorine disinfectants decreases.

**Pool**

A subset of an aquatic venue. Pools are designed to hold impounded/standing water for total or partial bather immersion. Unless otherwise distinguished as a specific type of aquatic venue, the term *pool* as used in this document is intended to include all aquatic venues.

**Pool decks**

The hardscape surface areas beyond the perimeter deck within the aquatic facility enclosure. Pool decks are regularly trafficked and made wet by bathers. Landscape areas are not included in this definition. “Dry decks” are pedestrian surface areas that are not subject to frequent splashing or constant wet foot traffic.

**Pool slide**

An attraction that allows users to slide from an elevated height into a pool. Pool slides have a configuration as defined in The Code of Federal Regulations (CFR) Ch. II, Title 16 Part 1207, or are similar in construction to a playground slide. They shall include children’s (tot) slides, pool slides, and all other non-flume slides that are mounted on the pool deck or within the basin of a public swimming pool. Pool slides have a flow rate of less than 100 gpm and do not exceed 10 feet in height.

**Portable vacuum system**

A modular vacuum system normally consisting of a dolly-mounted pump, filter, and power cord.

**Potable [water]**

Water that does not contain objectionable pollution, contamination, minerals, or infection, and is considered satisfactory for domestic consumption.

**Preventive medicine**

The term *preventive medicine* as referenced in this document refers to environmental health or public health personnel responsible for conducting recreational water facility surveillance on installations in accordance with AR 40-5 and DA PAM 40-11. Preventive medicine includes enlisted personnel and non-commissioned officers with military occupational specialty 68S, Environmental Science and Engineering Officers (ESEO), and equivalent civilian public health personnel. The reference to preventive medicine also applies to military and civilian technicians

and officers from other military branches with similar public health duties and responsibilities at joint bases.

**Protozoa**

One-celled microorganisms, including amoebae, ciliates, flagellates.

**Recessed steps**

A means of pool ingress/egress similar to a pool ladder but with individual treads recessed into the pool wall.

**Recirculation system**

A system that contains a pump, filtration system, and chemical treatment system for the purpose of disinfecting and filtering pool water.

**Recreational water facility**

A body of water which has been constructed, installed, modified, or improved for the purpose of public swimming or bathing. Under the control of a person, a recreational water facility includes, but is not limited to, bathing beaches; swimming, wading, and diving pools; aquatic play features; spas, hot tubs, therapeutic pools, hydrotherapy pools, and whirlpools.

**Residual [chlorine]**

The quantity of chlorine (expressed in mg/L or ppm), in excess of the chlorine demand, remaining in water, sewage, or effluents after a selected contact period of time; the difference between the chlorine dose and the chlorine demand.

**Runout**

That part of a water slide where riders are intended to decelerate and/or come to a stop. The runout is a continuation of the water slide's flume surface.

**Safety Plan**

A written document that states the procedures, requirements and/or standards for pre-service employees, communications, aquatic safety team members, in-service training, staffing, rescue skill competency, lifeguard rotation procedures, lifeguard management, emergency action plan, incident follow-up, bloodborne pathogen exposure control, emergency closure, and single lifeguard situations (if applicable).

**Sanitary Survey**

An inspection conducted to evaluate site-specific geographic and environmental conditions in a watershed. The sanitary survey report states the findings and recommendations concerning use of the watershed for a particular purpose (such as a natural bathing facility).

**Saturation Index**

A mathematical representation or scale representing the ability of water to deposit calcium carbonate or to dissolve metal, concrete, or grout.

**Secondary disinfection systems**

Those disinfection processes (such as UV, ozone) which are required, in certain circumstances, to meet the minimum standards of this bulletin and are in addition to the requirements of section 5.0 of this bulletin.

**Skimmer**

A device installed in the pool wall for the purpose of removing floating debris and surface water to the filter. Skimmers shall include a weir to allow for the automatic adjustment to small changes in water level, maintaining skimming of the surface water.

**Slurry**

A watery mixture of an insoluble or partially soluble material (such as lime).

**Spa**

A permanent structure intended for use with either warm or cold water but not intended for prolonged exposure. Spa structures are intended for bathing or other recreational uses and are not usually drained and refilled after each use. A spa may include, but is not limited to, hydrotherapy, air induction bubbles, and recirculation. In this bulletin, the term “spa” also refers to hot tubs and whirlpools.

**Splash pad**

*Synonyms: splash deck, wet deck. See “Spraygrounds.”*

**Spraygrounds**

The specific areas consisting of the play surface, features that spray bathers with recirculating water, and drains, upon which there is no standing water on the surface. For the purposes of this bulletin, only those spraygrounds designed to recirculate water and intended for public use and recreation shall be regulated. Spraygrounds are also commonly referred to as spray pads or splash pads.

**Sprayground collection tank**

The vessel used to collect the water that has been sprayed on the spray pad and returned through the spray pad drains.

**Sprayground features**

The devices and plumbing used to convey the treated water to the spray pad to spray the patrons.

**Spray pad**

See “Spraygrounds.”

**Substantial renovation**

The renovation of a major component or substantial structural part of an aquatic venue that either—

- a. Materially increases the value of the property,
- b. Substantially prolongs the useful life of the venue, or
- c. Adapts the venue to a new or better use.

**Supplemental disinfection systems**

Those disinfection processes or systems which are optional and not required on an aquatic venue for health and safety reasons. They may be used to enhance overall system performance.

**Trihalomethanes or THM**

Chemical compounds in which three of the four hydrogen atoms of methane (CH<sub>4</sub>) are replaced by halogen atoms. Trihalomethanes are environmental pollutants, and many are considered carcinogenic.

**Turbidity**

The cloudy appearance of water due to the presence of fine suspended particles in it that interfere with the passage of light.

**Turnover**

The amount of time necessary for a pool’s circulation system to handle as many gallons of water as the pool holds. The unit of measure for a “turnover” is depicted as hours.

**Turnover rate**

The number of times per day a complete turnover cycle occurs. For example, a 6-hour turnover is equivalent to a turnover rate of four [24 hours per day ÷ 6 hours per turnover = 4 turnovers per day]; a 2-hour turnover yields a turnover rate of 12. A short turnover time yields a high turnover rate, which results in more water being filtered each day.

**Underwater ledge**

A continuous step in the pool wall that allows swimmers to rest by standing without having to tread water; also known as a “toe ledge.”

**Wading pool**

A special purpose pool intended for use by children. The depth of a wading pool does not exceed 2 feet (0.6 m).

**Water slide**

An attraction having a configuration that enables users to slide into a pool from an elevated height. A water slide must consist of one or more **flumes**, landing areas, **catch pools**, or slide runouts, and must be equipped with facilities for the **disinfection** and chemical treatment of the water.

**Waterborne disease**

Disease that is spread by swallowing, breathing in mists or aerosols of, or having contact with contaminated water. Waterborne disease can include infectious or chemical causes of disease, including chemicals that evaporate from the water and cause health problems. Waterborne disease can also include a wide variety of infections, including gastrointestinal, skin, ear, respiratory, eye, neurologic, and wound.

**Wave pool**

Any pool designed to simulate breaking or cyclic waves for the purpose of general play or surfing.



By Order of the Secretary of the Army:

RAYMOND T. ODIERNO  
*General, United States Army*  
*Chief of Staff*

Official:

A handwritten signature in black ink, appearing to read "Gerald B. O'Keefe". The signature is written in a cursive style with a large initial "G" and a distinct "B" and "O'Keefe" following.

GERALD B. O'KEEFE  
*Administrative Assistant to the*  
*Secretary of the Army*

Distribution:

This publication is available in electronic media only and is intended for command levels C, D, and E for the Active Army, the Army National Guard/Army National Guard of the United States, and the U.S. Army Reserve.

PIN: 051240-000